



Shed no. L-7838/3, Near Dhiraj Can, GIDC Industrial Estate, Ankleshwar - 393002, Dist. Bharuch, Gujarat, India.
Email: info@vovacengineers.com / service@vovacengineers.com | Office Contact: +91 26462 39811 / +91 70960 12867
Web: www.vovacengineers.com





ABOUT US

VOVAC ENGINEERS

VOVAC ENGINEERS is proud of its reputation as an ethical company with a dynamic can-do attitude which not only provides top quality manufacturing services, but also provides comprehensive refurbishment services with its efficient service capability to all its valuable customers. With our special focus on after sales we make sure that our service backup for any of our product or services to remain at par.

Our Company is an authorized dealer for HHV Pumps and Garuda Pumps and has been successful in the field of sales and services of Dry Screw/Claw vacuum pump, Root blower pump, Rotary Vane Vacuum Pump, Rotary Oil Sealed Vacuum Pump, Water Ring Vacuum Pump, Centrifugal pump, Mechanical Single/Double seals and Agitator seals.

Our proactive approach guarantees that we consider all aspects of our product condition and operating history to determine the root cause of any problems. Our service is responsive dependable and driven by your needs.

Engineer Your Aspiration With Us

Authorised Dealer.



HHV PUMPS
Vacuum Technology Solutions and Services





DP 400t & DP250T MULTI-STAGE DRY VACUUM PUMP



HHV Pumps introduced the new version of DP in 2016. Over the last three and a half years, we have been successful in supplying more than five hundred pumping systems for Chemical and Pharmaceutical applications. Based on the feedback from customers and with an aim towards increasing pump life, the new indirect cooling version of the Dry Vacuum Pump, DP300 is being launched with two variants – DP250T and DP400T.

The advantages of the new range of pumps are highlighted below.

DP 400T DP250T

- DP400TS is equipped with an indirect cooling mechanism based on, Thermosiphon principle. A liquid coolant is filled around the stators connected to a heat exchanger. Cooling water will flow in and out of the heat exchanger.
- Constant temperature is maintained throughout the pumping cycle with the help of a Thermostatic Control Valve and Temperature Detectors.
- This temperature control system helps in preventing condensation/deposition of chemicals in the stages. This is achieved through changing and maintaining required temperature as defined by the process chemicals.
- Cartridge type water tubes in the heat exchanger eliminate the risk of blockages in the pump casing over a period of time.
- Unidirectional flow of water through the heat exchanger in 8mm tubes generates better cooling as compared with competition.

Models: DP400T – 360m³/h
DP250T – 250m³/h

Versions available:

Version	Models	Details
Basic	DP250T/400T	Bare pump for non-Pharmaceutical or non-Chemical applications
Intermediate	DP250TSA-1 or 2 DP400TSA-1 or 2	Pump with suitable accessories for Pharmaceutical applications
Advanced	DP250TSB-1 or 2 DP400TSB-1 or 2	Pump with suitable accessories for Chemical (Harsh) applications

Nomenclature:

Nomenclature:

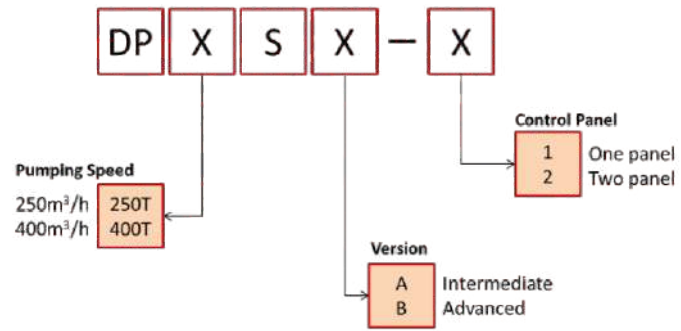

For internal circulation only. All rights reserved. © HHV Pumps Pvt. Ltd. 2020

Versions:

Features / Versions	Basic (Clean Application)	Intermediate		Advanced	
		(Two Panel)	(Single Panel)	(Two Panel)	(Single Panel)
Models	DP250T DP400T	DP250TSA-2 DP400TSA-2	DP250TSA-1 DP400TSA-1	DP250TSB-2 DP400TSB-2	DP250TSB-1 DP400TSB-1
Heat Exchanger	✓	✓	✓	✓	✓
Shaft Seal Purge	✓	✓	✓	✓	✓
Silencer*	✓	x*	x*	x*	x*
Temperature Control Valve	-	✓	✓	✓	✓
Solvent Tank	-	✓	✓	✓	✓
Inlet N ₂ Purge	-	✓	✓	✓	✓
Pressure Transmitter (Exhaust)	-	x	x	✓	✓
Pressure Transmitter (Inlet)	-	x	x	✓	✓
Resistance Temperature Detector	-	x	x	✓	✓
Inlet Isolation Valve	-	✓	✓	✓	✓
Inlet Filter – MS	-	✓	✓	x	x
Inlet Filter – SS	-	x	x	✓	✓
FLP Pendant (on DP system frame)	-	✓	-	✓	-
Control Panel (Non-FLP)	-	✓	-	✓	-
Control Panel (FLP)	-	-	✓	-	✓
Pipelines (SS304)	-	✓	✓	✓	✓

The proposed DPXXXTS will include the following changes with respect to the existing DP300S

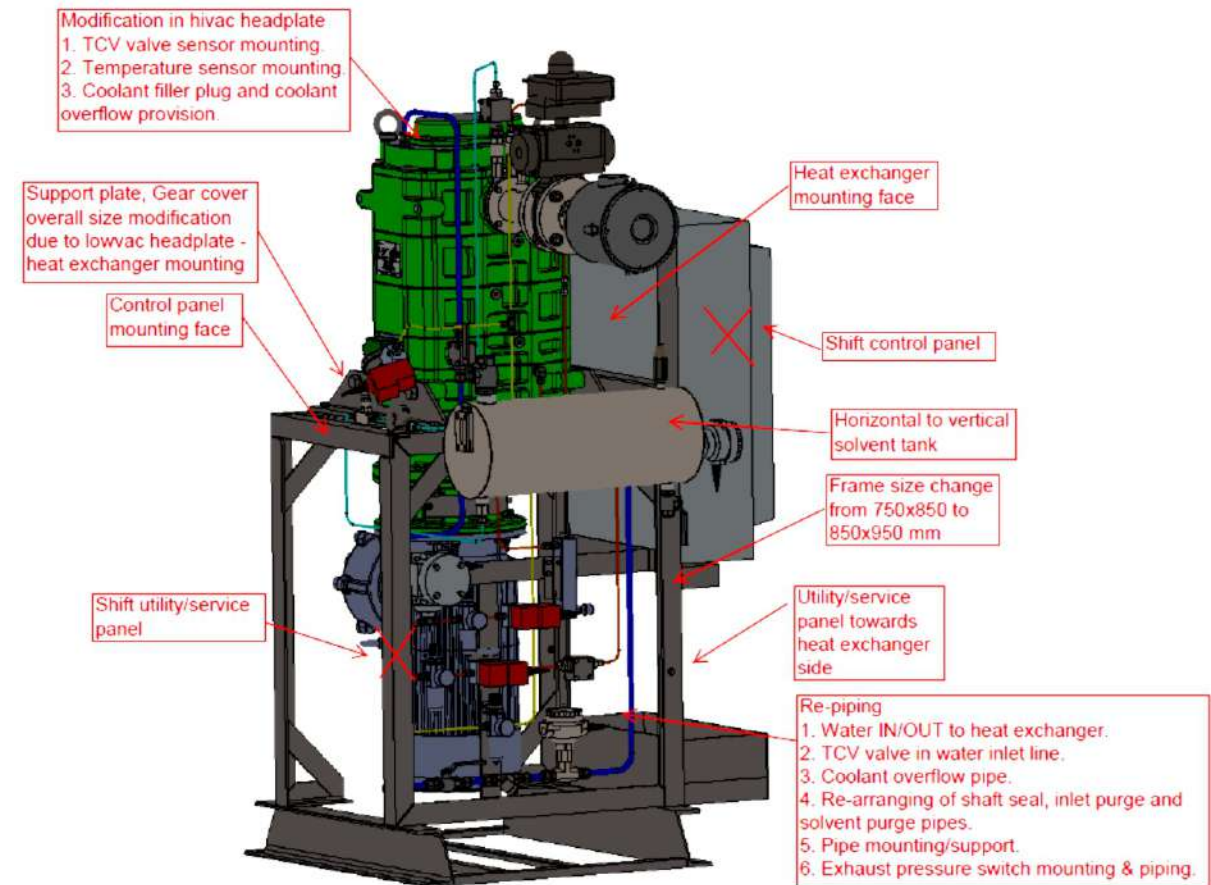
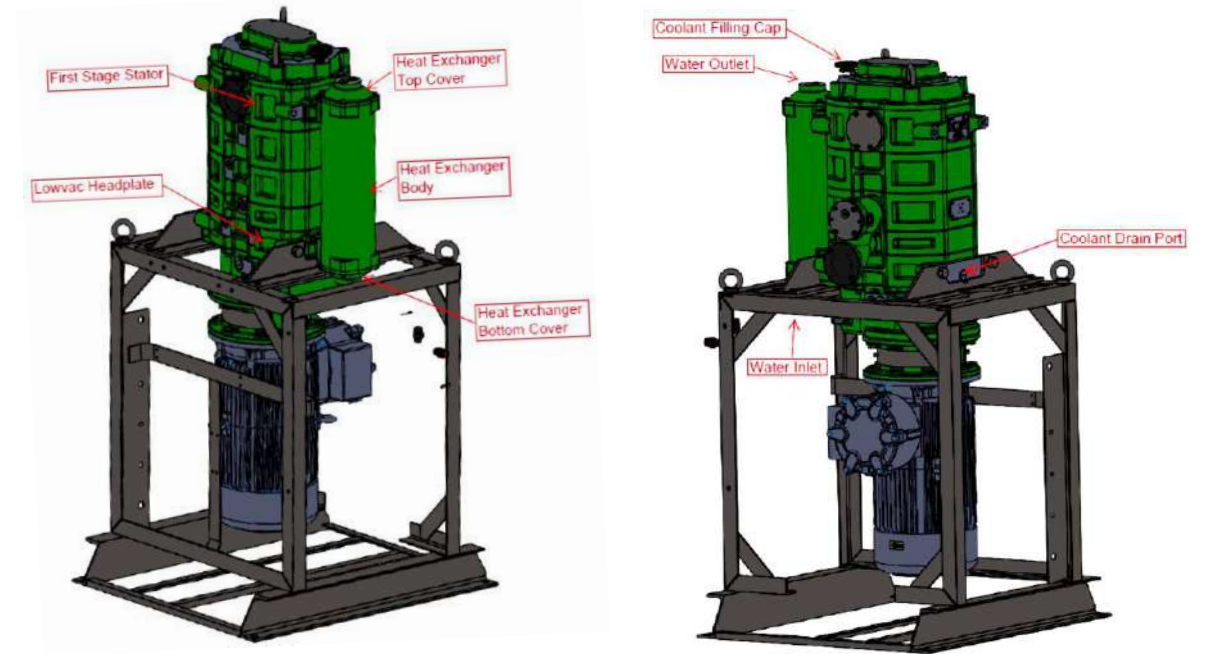



Variants are proposed to take care of the following applications commonly faced by us till date.

Industry	Markets	Applications	Basic	Intermediate	Advanced
Process Vacuum	Chemical	Aromatic Extraction			•
		Tray Drying		•	•
		Filtration	•		
		Distillation (Common solvents)		•	•
		Distillation (Reactive chemicals)			•
	Pharmaceutical	Short Path Distillation		•	•
		Distillation (Common solvents)		•	•
Distillation (Reactive chemicals)				•	
Freeze Drying	Freeze Drying (Industrial)	•			
Electrical & Power	Transformer Drying	•			
Industrial Vacuum	Vacuum Heat Treatment	Vacuum Furnace	•		
	Evacuation	Cryogenic Tank Evacuation	•		
Thin Film Deposition (Non-Semiconductor)	Solar (Photovoltaic)	Solar Lamination	•		

- Recommended
- Optional

DIMENSIONS

DP300

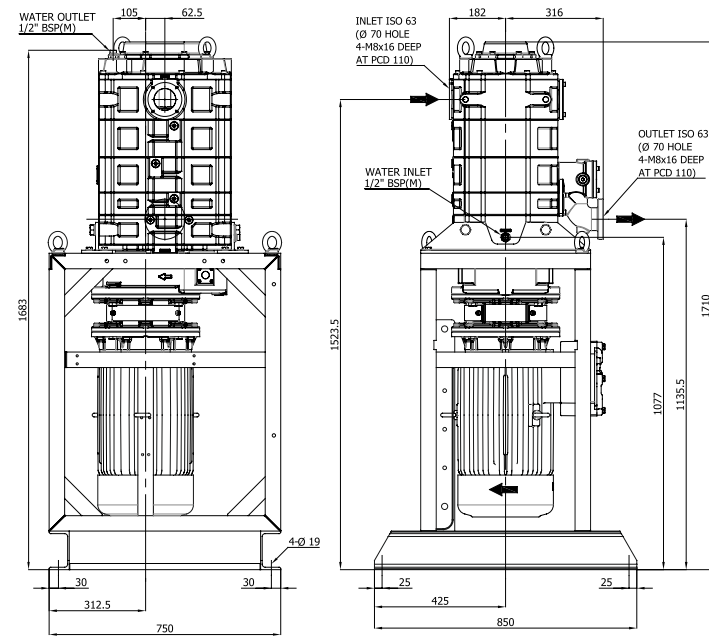

DP300H

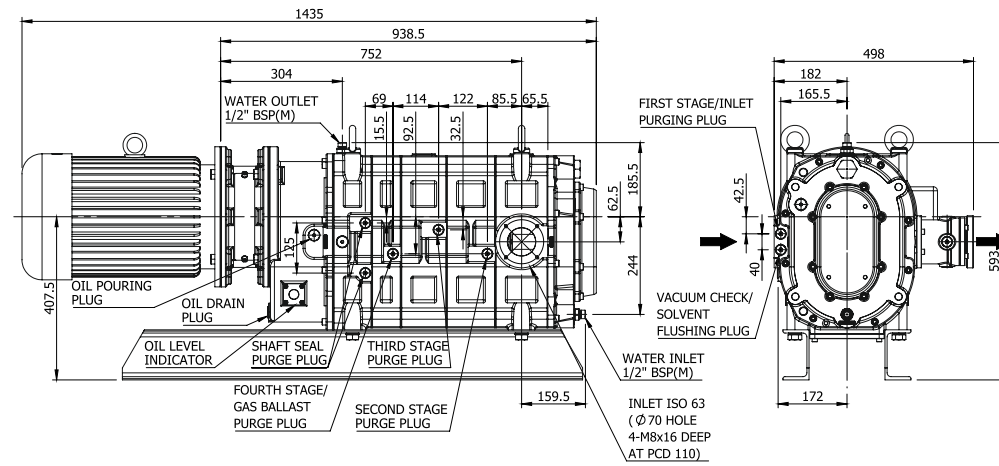

DP300S

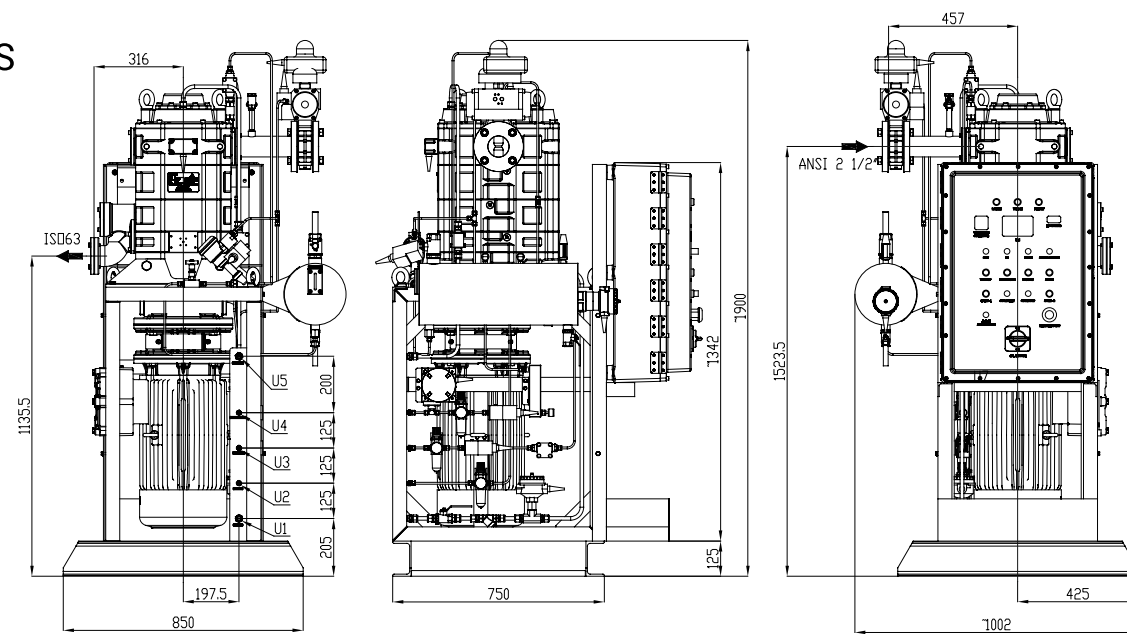

All dimensions indicated above are in mm



DP300

MULTI-STAGE DRY VACUUM PUMP



DP 300 a multi-stage Dry Vacuum Pump is composed with a pair of lobes and a pair of claw rotors rotating opposite in a synchronous way within the pump casing to from suction and discharge operation. Oil-free, non-contacting, four stage roots and hook & claw arrangement makes it a more suitable for pumping air and other suitable gases. IT provides consistent vacuum with high efficiencies, lowest cost of ownership with adequate safety and performance standards. The new pump is of 300m³/h capacity with an ultimate vacuum of less than 1mbar.

DP300S-Compact Multi-stage Dry Vacuum Pumping System. A fully automated and self-sustained vacuum pumping system designed with all essential safety features makes in industry ready and a plug-and-play standalone unit.

**DP300
DP300S
DP300H**

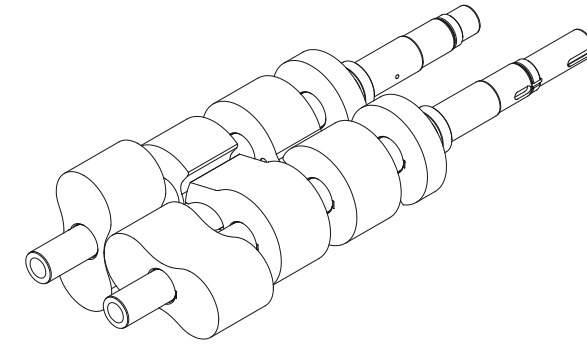

DP 300 FEATURES

Four stage compression

Faster air removal and higher rate of compression

Compact design

Slim construction even with the availability of water cooling jacket

Vertical mount

Self-draining technology and a vertical mount design make the pump more versatile and rugged

Water cooled

Limits temperature rise to prevent overheating and excess thermal expansion

Cartridge-type inlet side bearing

Grease lubricated roller bearing ideal for supporting radial and axial loads Easy replacement of inlet side roller bearing and seals without removing stages

Angular contact bearing

Double row angular contact bearings near the motor take care of simultaneously acting radial and axial loads

Relief valve

A third stage relief valve avoids high pressure build up within stage compression cycle, if the pump crosses 300mbar

DP300S FEATURES

Simple yet intelligent direct cooling

Direct cooling mechanism with safety interlocks shuts down the pump in case of low/no water supply. A Y-strainer in the main low line helps reduce any impurities lowing towards the pump. Temperature sensor mounted near the exhaust of the pump and a lame-proof grad water low sensor is programmed to continually monitor the pump

Inlet Purge

Protection from process substances entering into the pump chamber and pipe lines through purging a high pressure nitrogen at the inlet.

Shaft Seal purge

It is essential to maintain shaft seals at a positive pressure during operation helping to prevent entry of corrosive/toxic gases toward the pumps gear cover. Life of shaft seals increases as we eliminate the risk of damage that may cause from debris or any other corrosive/toxic gases.

A controlled and customizable feature helps the user to determine the purge frequency based on the usage and application

Solvent Purge

Internal surfaces of the pumps are more prone to corrosion and by-product settlement. This is prevented by running the solvent used for distillation. The solvent purge will rinse the pump internal and keep it safe from possible corrosion and process substances.

DP300S

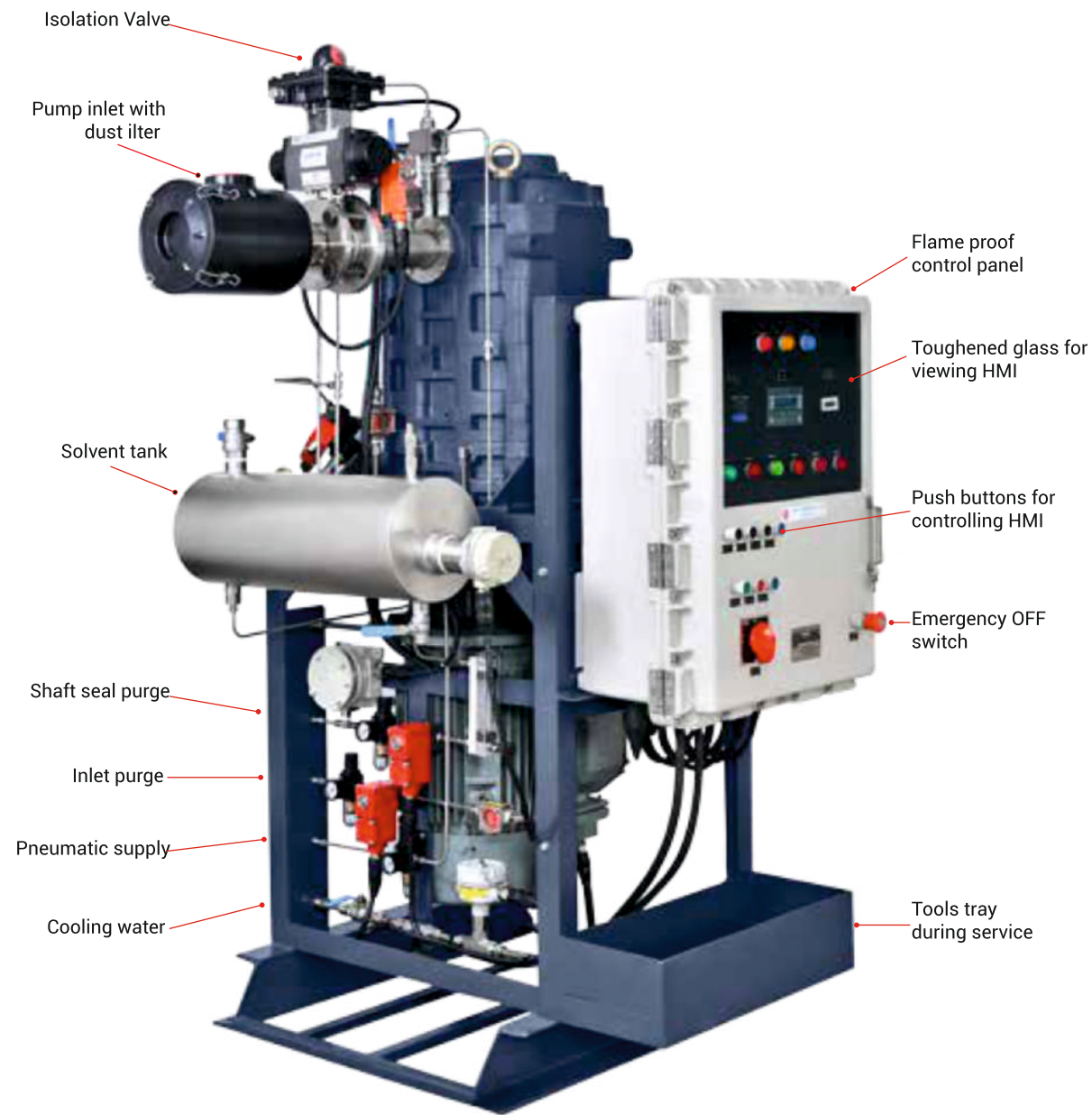

Industry/Markets

- Chemical and Process Industries
- Food
- Medical
- Electrical & Power

Typical Applications

- Distillation
- Drying
- Freeze drying
- Short path distillation

DP300S with RD1500 Vacuum Pumping System (VPS)

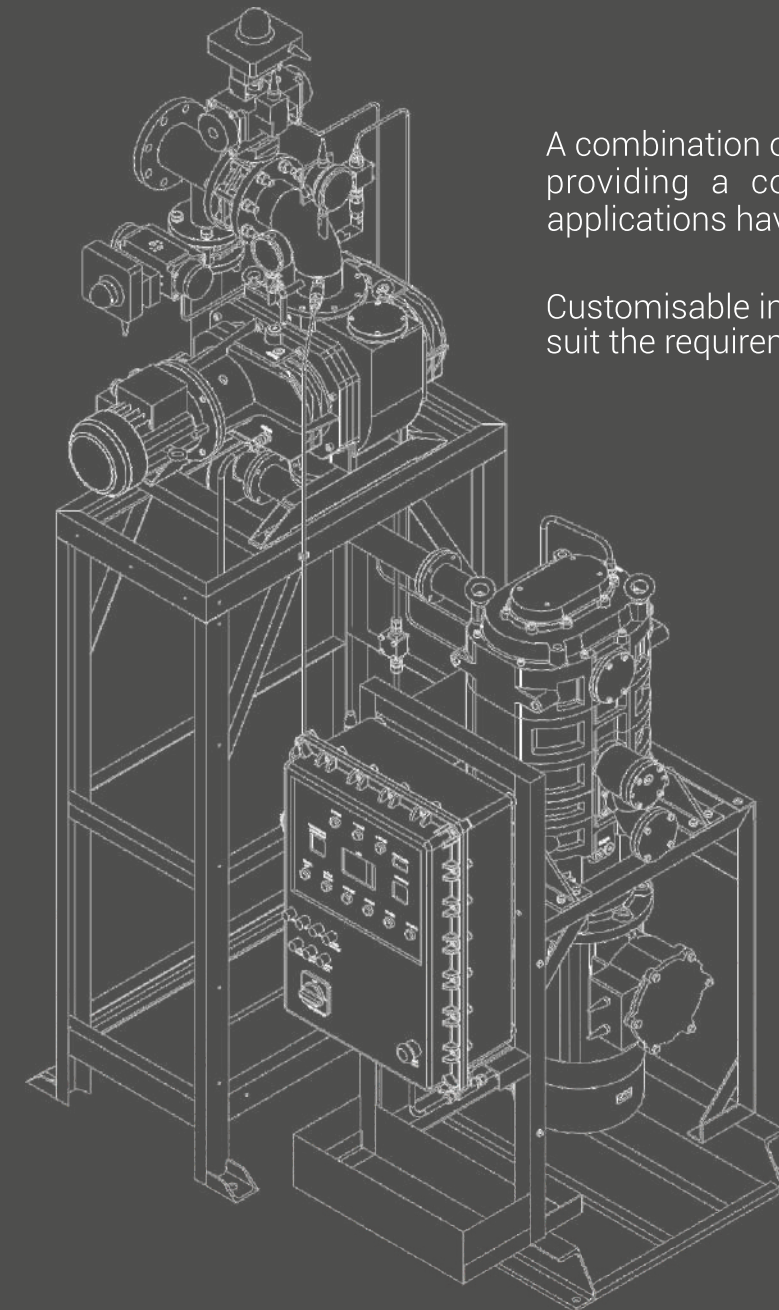

A combination of DP300 with RD1500 is offered providing a complete pumping solution to applications having larger volumes.

Customisable instrumentation and accessories to suit the requirement.

Industry/Markets(DP300+RD VPS)

- Chemical and Process Industries
- Food
- Medical
- Electrical & Power

Typical Applications (DP300+RD VPS)

- Distillation
- Drying
- Filtration
- Solvent recovery
- Centralised vacuum – Pharmaceutical laboratories
- Freeze drying
- Short path distillation
- Steam sterilization



SPECIFICATIONS

Particulars	Unit	DP300/DP300S	DP300H
Description/Frequency/Phase	Hz	50	50
Orientation	-	Vertical	Horizontal
No. of stages	-	4	4
Construction	-	1 root + 3 claw	1 root + 3 claw
Maximum pumping speed	m ³ /h	300	300
Ultimate pressure (total pressure)	mbar	0.05	0.05
Motor power	kW	11	11
Weight	kg	565	556
Noise level**	dB(A)	78	78
Inlet connection	-	ISO63	ISO63
Exhaust connection	-	KF50	KF50
Gearbox oil capacity	L	3.5	3.5
Recommended oil (supplied)	-	ISOVG 150	ISOVG 150
Cooling system type	-	Direct water-cooling	Direct water-cooling
Cooling-water low	l/min	5 to 10	5 to 10
Supply temperature range	°C	5 to 35	5 to 35
Cooling-water supply pressure	bar G	2 to 10	2 to 10
Shaft-seals air/nitrogen purge	-	Yes	Yes
Pressure relief valve	-	Yes	Yes
Overall dimensions (Length x Width x Height)	mm	850x730x1614	1435 x 498 x 593

PERFORMANCE CURVES

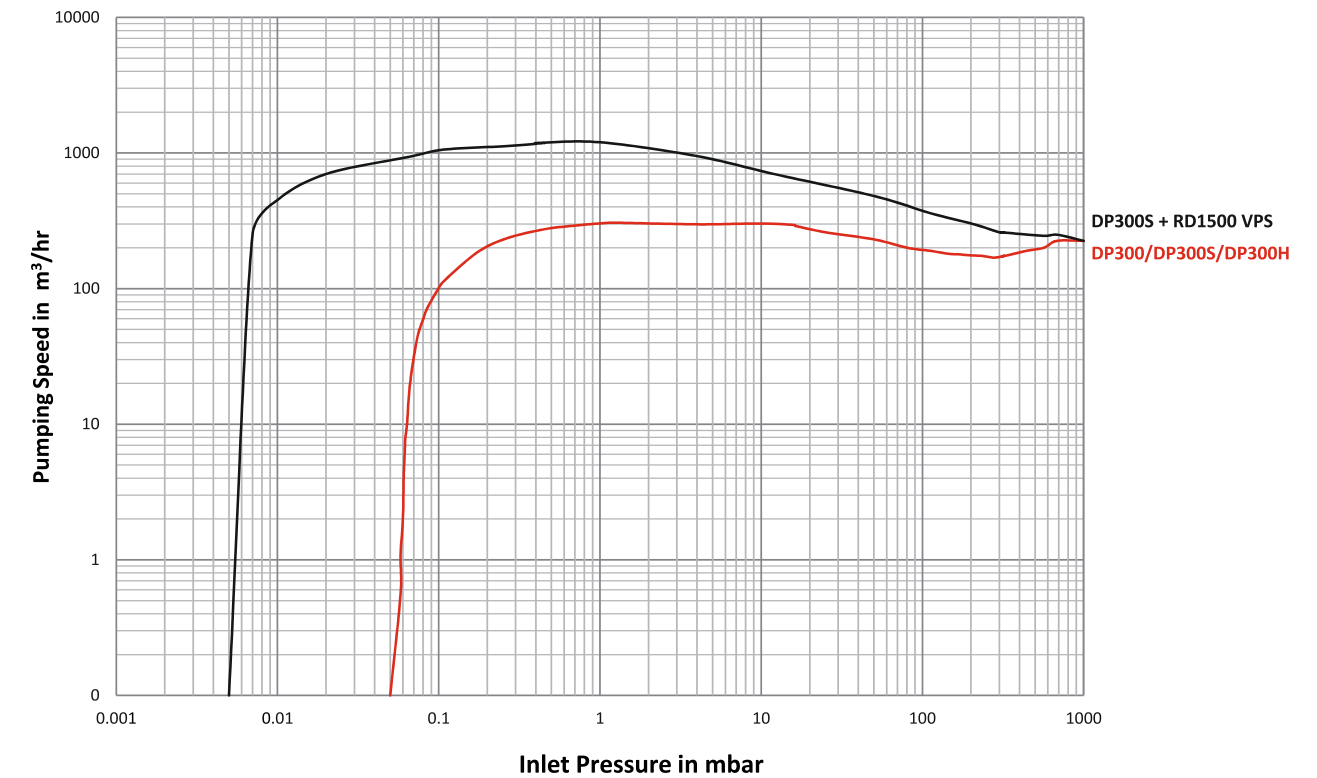

Function	Parameter	Recommended
Shaft Seal Purge (N ₂)	Seal purge supply pressure	2 to 10 bar g
	Regulated pressure of purge to shaft seal (above exhaust back pressure)	0.3 to 0.5 bar g
	Maximum seal purge low at regulated pressure	20 LPM
	Connection, supply interface	3/8" BSP (F)
Cooling Water	Supply temperature range	5 to 35 °C
	Maximum supply pressure	10 bar g
	Minimum required pressure differential across supply and return	2 bar g
	Typical heat removed from pump by cooling water	5.5 kW
	Maximum water consumption with pump operating temperature*	4 LPM
	Cooling water low	4 to 10 LPM
	Connection, supply interface	1/2" BSP (M)
	Cooling water supply, water quality: Ryznar stability index	6.5 – 7
Connections	Cooling system type	Direct water cooling
	Warm down	15 min**
	Shaft seal purge	3/8" BSP (F)
	Cooling water inlet	1/2" BSP (M)
	Cooling water outlet	1/2" BSP (M)
	N ₂ purge and gas ballast purge	3/8" BSP (F)

* Pump at ultimate vacuum with a cooling water supply temperature of 20°C and an ambient temperature.

** 5 min solvent purge + 10 min inlet purge.

DIMENSIONS

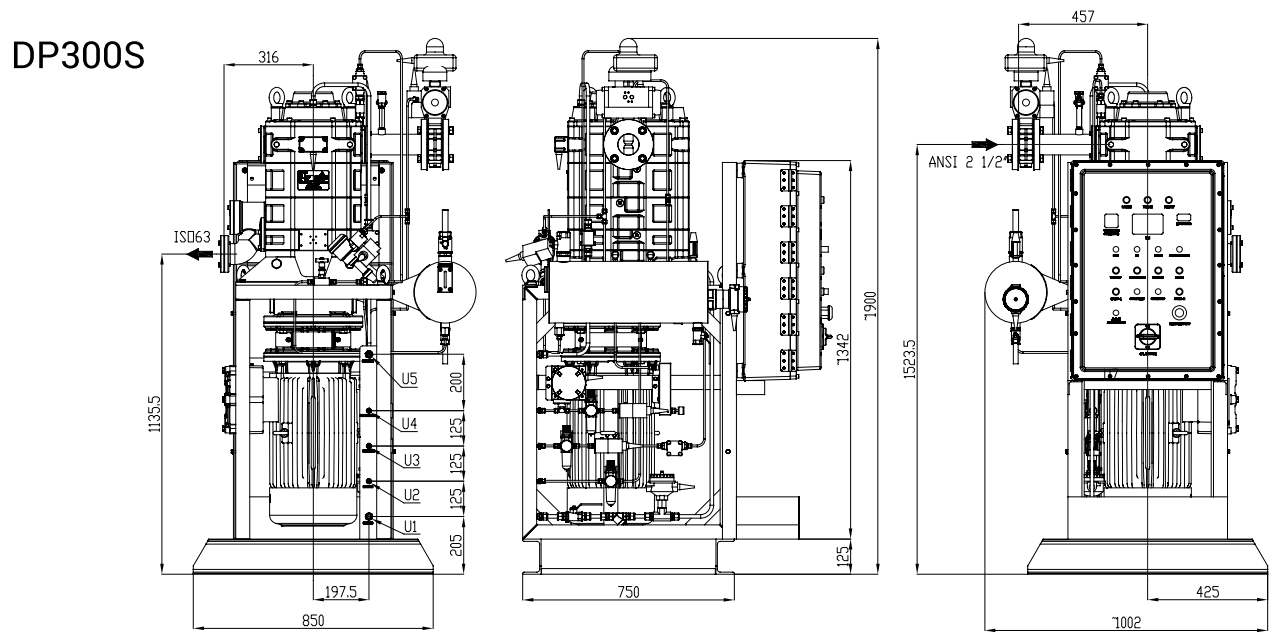
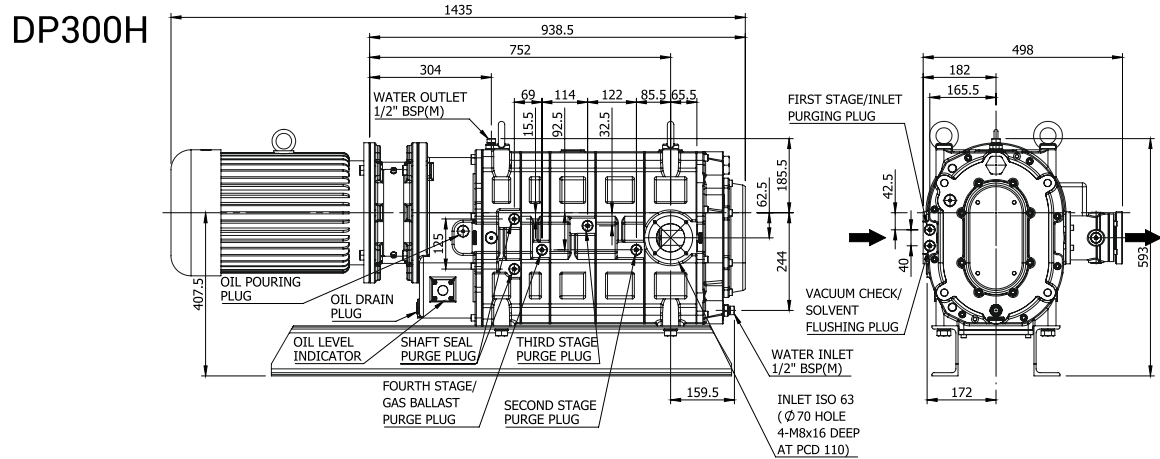
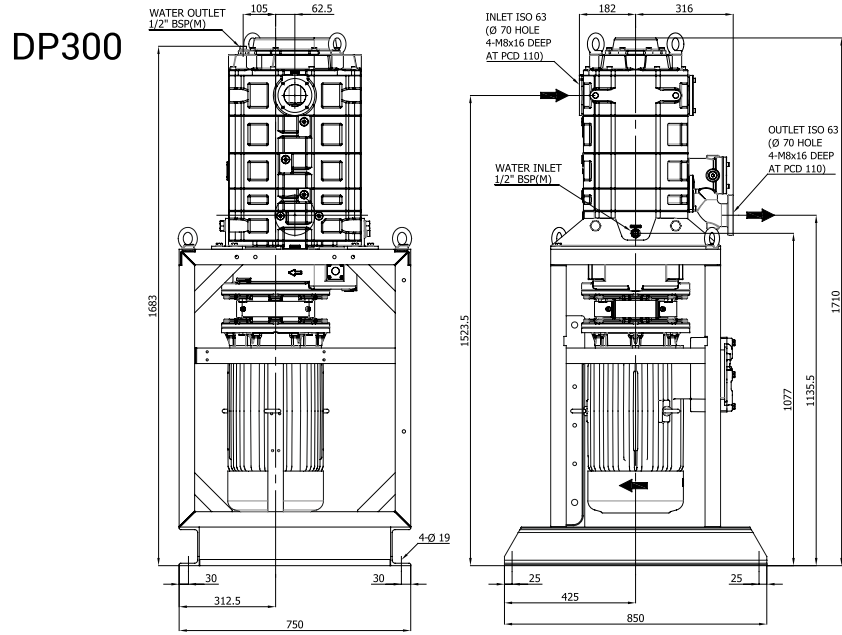

All dimensions indicated above are in mm

VOVAC ENGINEERS
Engineer Your Aspiration With Us



HHV PUMPS
Vacuum Technology Solutions and Services



SP SERIES SIGLE STAGE VACUUM PUMPS

Rugged, Single stage, oil sealed, rotary vane vacuum pumps of global standard



SP series is one of our fastest moving product ranging from 17 to 300m³/h pumping speeds. The pumps are suitable for various applications needing vacuum in a spectrum of few hundred mbar to 1mbar.

Variable gas ballast technique ensures lesser oil contamination.

SP16 | **SP100**
SP40 | **SP200**
SP65 | **SP300**

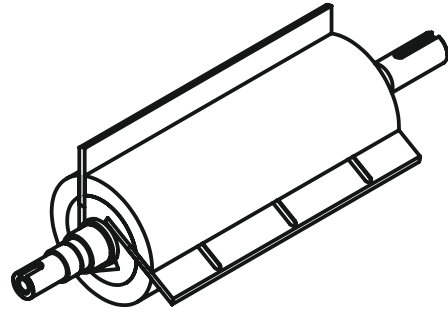

FEATURES

- Robust and compact
- High pumping speed even at low pressures
- Gas Ballast valve fitted as standard with easy access
- Exhaust mist filter with built-in bypass valve
- Quiet in operation
- Minimal vibration
- Integral anti-suck back valve
- Less oil consumption
- Air-cooled
- Easy to service

TYPICAL APPLICATIONS

- Resin infusion (wind shield)
- Job holding (CNC), pick & place (gantry robot)
- Vacuum material conveying (powder transfer)
- Tray drying, roto-cone evaporator
- Agitated thin film dryer (ATFE)
- Transformer/capacitor vapour phase drying (electrical)
- Vacuum filtration (Chemical)
- Solar lamination
- Resin impregnation
- Capsule filling, blister packing (Pharmaceutical)
- Food packaging

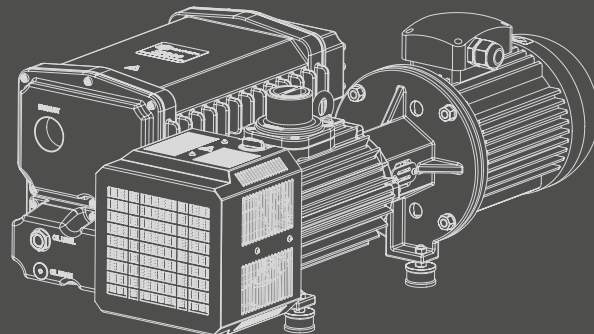

INDUSTRY/MARKETS

- Coating & deposition
- Food processing
- Metallurgy/Furnace
- Power engineering
- Automotive
- Pharmaceutical
- Packaging
- Research & development
- Central vacuum systems
- Laminator

PERFORMANCE CURVES

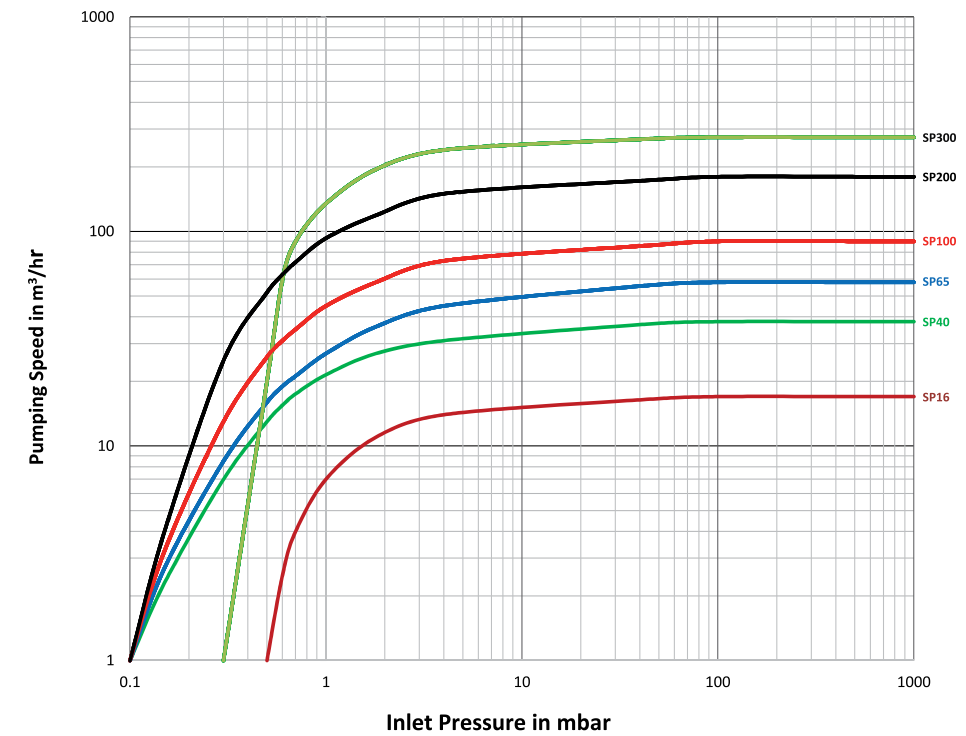

SPECIFICATIONS

Particulars	Unit	SP16	SP40	SP65	SP100	SP200	SP300
Nominal pumping speed @ 50Hz	m³/h (L/min)	17 (284)	43 (717)	65 (1083)	102 (1700)	192 (3200)	300 (5001)
Ultimate vacuum (Total pressure)	Gas ballast closed in mbar (Torr)	≤ 0.5 (0.37)	≤ 0.1 (0.07)	≤ 0.1 (0.07)	≤ 0.1 (0.07)	≤ 0.1 (0.07)	≤ 0.3 (0.22)
	Gas ballast open in mbar (Torr)	≤ 1.5 (1.125)	≤ 1.5 (1.125)	≤ 1.5 (1.125)	≤ 1.5 (1.125)	-	-
	Small gas ballast in mbar (Torr)	-	-	-	-	≤ 0.8 (0.6)	≤ 0.8 (0.6)
	Standard gas ballast in mbar (Torr)	-	-	-	-	≤ 1.5 (1.125)	≤ 1.8 (1.35)
	Big gas ballast in mbar (Torr)	-	-	-	-	≤ 2 (1.5)	≤ 2.5 (1.87)
Water vapour pumping capacity	kg/h	0.3	0.9	1.4	2.2	1.5, 2.5, 4***	2.4, 4.5, 6***
Water vapour tolerance	mbar	40	40	40	40	20, 30, 40***	20, 30, 40***
Nominal power rating at 50Hz	kW (HP)	0.75 (1)	0.75 (1)	1.5 (2)	2.2 (3)	3.7 (5)	5.5 (7.5)*
Motor rotational speed at 50Hz	rpm	1500	1000	1500	1500	1500	1500
Weight	kg (lb)	29	53	59	90	139	193
Inlet connection		G 3/4" F	G 1 1/4" F	G 1 1/4" F	G 1 1/4" F	G 2" F	G 2" F
Outlet connection		G 3/4" F	G 1 1/4" F	G 1 1/4" F	G 1 1/4" F	G 2" F	G 2" F
Oil capacity	Lts	1	1.8	1.8	2	7	9
Recommended oil	Standard	IG68					
Power supply		Three Phase 415V, 50Hz**		Three Phase 415V, 50Hz			

- * One step higher size motor available
- ** Optional single phase motor available
- *** Small, Standard and Big Gas ballast

DIMENSIONS

SP16

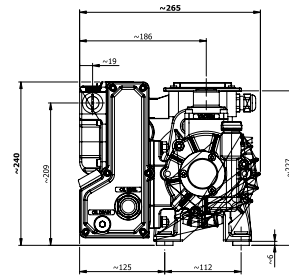
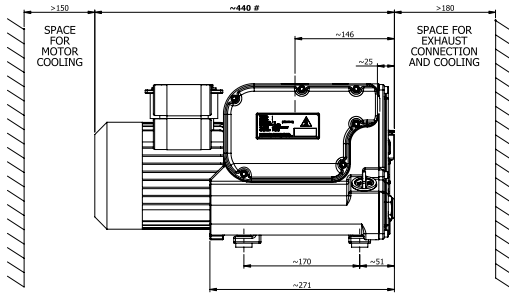

SP40

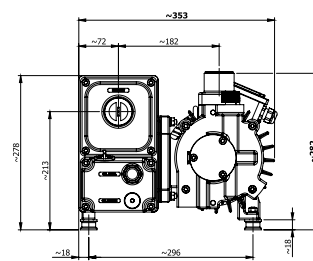
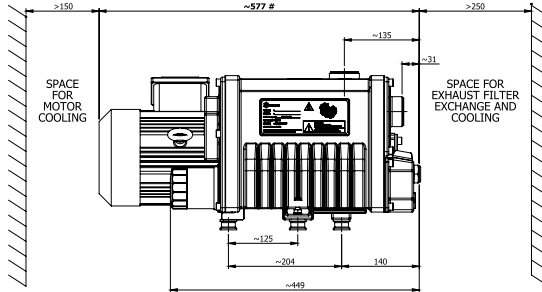

SP65

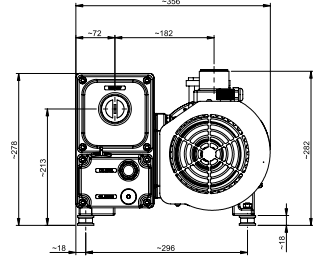
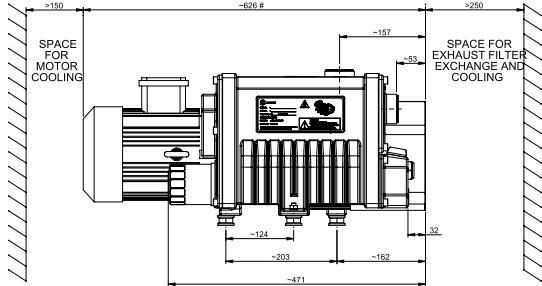

SP100

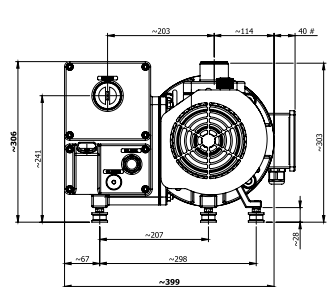
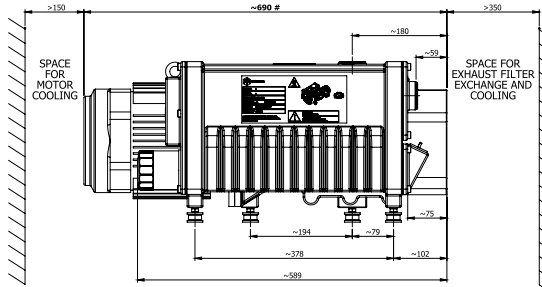

SP200

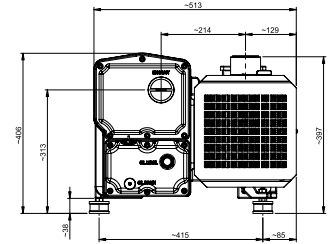
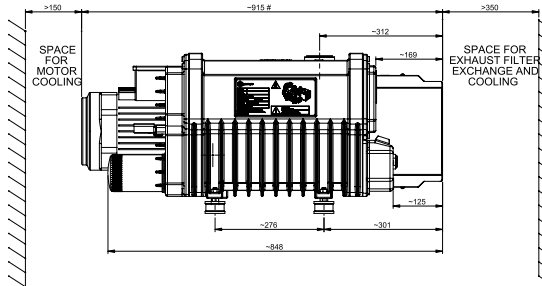

SP300

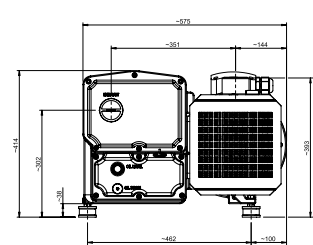
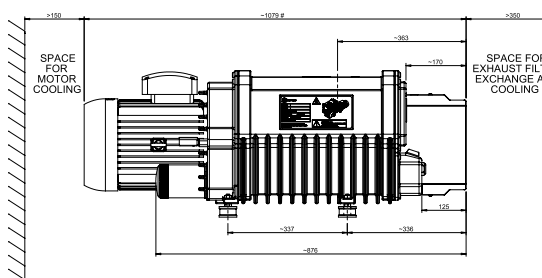

All dimensions indicated above are in mm

VOVAC ENGINEERS
Engineer Your Aspiration With Us



HHV PUMPS
Vacuum Technology Solutions
and Services



ED30A
RELIABLE AND CONSISTENT



Two stage oil sealed, rotary vane vacuum pumps designed for durability.

ED30 Is A New Improved Design With A Better Vacuum Performance. The Pump Now Comes With An Improved Oil Circuit And New Concepts Introduced In Machining Of Parts, Giving The Pump More Consistency In Operation.

FEATURES

- » Rugged in construction for reliable performance
- » Built-in anti-suck back preventing oil back stream
- » Gas ballast feature to prevent vapour condensation
- » Performance testing in accordance with Pneurop 6602

INDUSTRY/MARKETS

- » Air conditioning and refrigeration
- » Aerospace
- » Chemical
- » Cryogenic
- » Defence
- » Electrical
- » Laboratories
- » Lighting
- » Metallurgy
- » Pharmaceuticals
- » Research and development

TYPICAL APPLICATIONS

- » Evacuation
 - AC & refrigeration pipe
 - Cryogenic storage tank
 - Light bulbs
 - R&D
- » Coating
- » Jewelry casting
- » High vacuum distillation
- » Freeze drying & lyophilisation
- » Furnace
- » Leak testing
- » Filtration
 - Transformer oil filtration
 - Chemical filtration



DIMENSIONAL DETAILS - ED30A

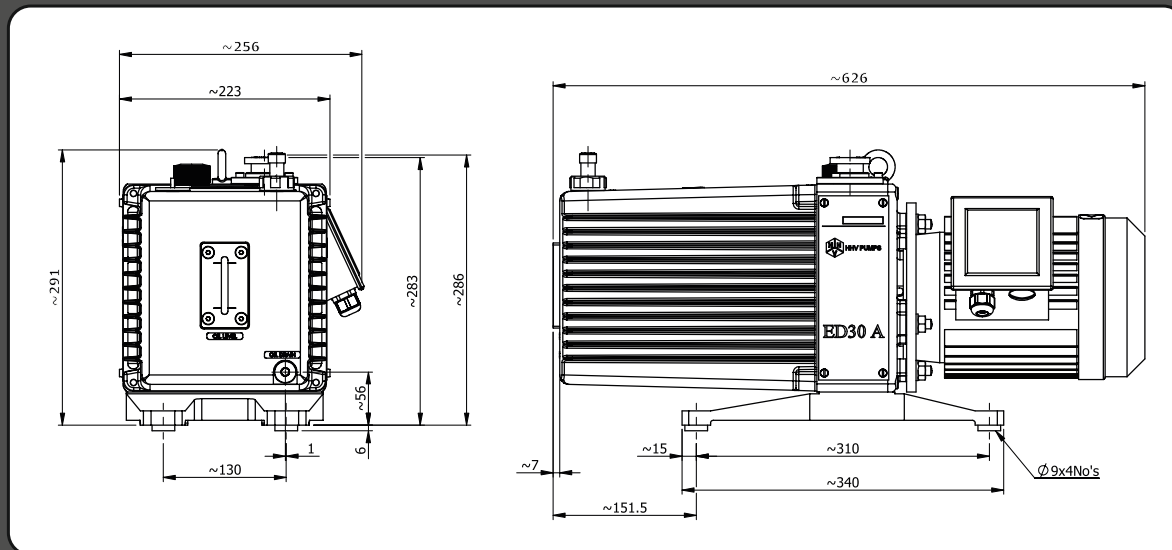

PERFORMANCE CURVES

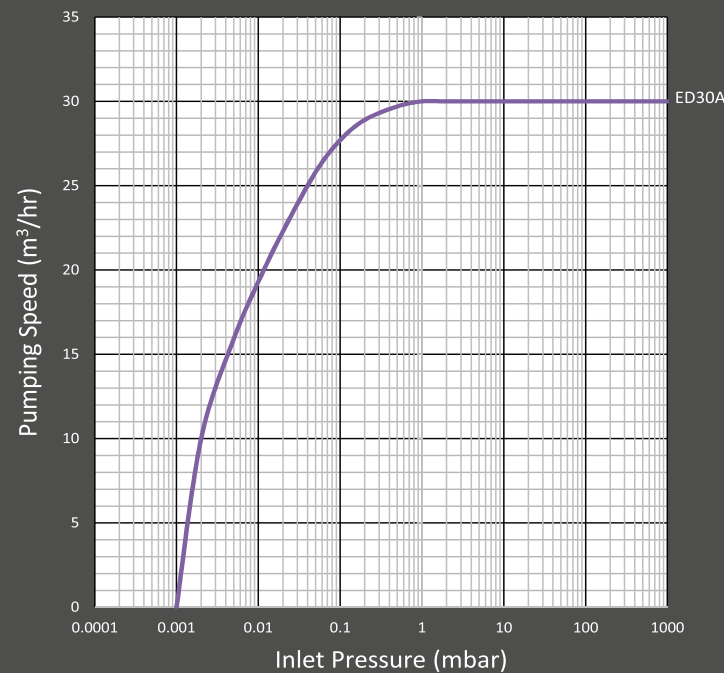

TECHNICAL SPECIFICATIONS

PARTICULARS	UNIT	ED30A
Nominal pumping speed @ 50Hz	m ³ /hr (L/min)	34.7 (500)
Ultimate vacuum (Gas Ballast Closed)	mbar (Torr)	1x10 ⁻³ (7.5x10 ⁻⁴)
Ultimate vacuum (Gas Ballast Open)	mbar (Torr)	5x10 ⁻² (3.75x10 ⁻³)
Pump Rotational Speed at no load @ 50 Hz	rpm	1440
Max. Nominal Power Rating @ 50 Hz	kW (HP)	1.1 (1.5)
Weight	kg (lb)	45 (99.2)
Inlet connection	Flange	KF25
Outlet connection	Nozzle OD	15mm
Oil capacity	Lts	3
Recommended oil	HHVP make	MD504
Electical		3P 380-440V (50Hz)

FEATURES

- » Robust and compact
- » Water cooled for continuous operation
- » Built-in anti-suck back preventing oil back stream
- » Built-in gas ballast feature for pumping condensable vapours
- » Rugged in construction for reliable performance
- » Proven operation in various applications
- » Performance testing in accordance with Pneurop 6602

APPLICATIONS

- » Chemical industries
- » Research and Development
- » Oil and Gas industries
- » Pharma and Laboratories
- » Electrical industries (Lamps and Tubes)
- » Metallurgical industries
- » Backing pump for Roots, Turbo, Diffusion and Cryogenic Pumps
- » Freeze Drying
- » Power industries
- » Vacuum furnaces
- » Cryogenic Pumps
- » Coating and Deposition
- » Vacuum impregnation

CP SERIES
BUILT TOUGH

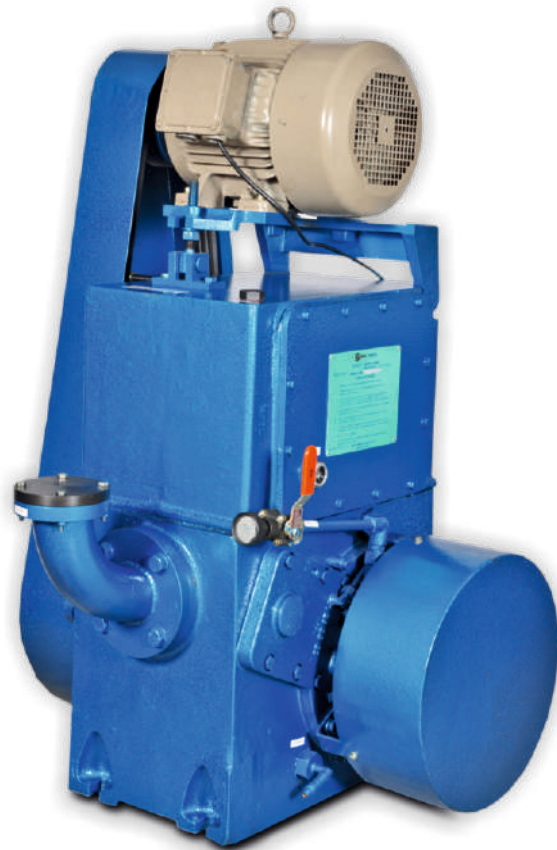

TECHNICAL SPECIFICATIONS

Pump Model	CP 250	
Nominal pumping speed	m ³ /hr	250
	cfm	147
	L/min	4100
Ultimate pressure	Gas Ballast Closed-mbar (Torr)	1x10 ⁻² (7.5x10 ⁻³)
	Gas Ballast Open mbar (Torr)	1x10 ⁻¹ (7.5x10 ⁻²)
Pump rotational speed at no-load	rpm	560
Maximum nominal power rating	kW	5.5
	HP	7.5
	Phase	3
	Power supply	410V ± 10%; 50Hz ± 5%
Weight	kg (lb)	720(1584)
Oil capacity	Litres	12
Inlet connection	ISO	75
Outlet connection	Nozzle OD	56mm
Recommended oil	HHVP Molecular Distilled Oil Grade MD-505	

PERFORMANCE CURVES

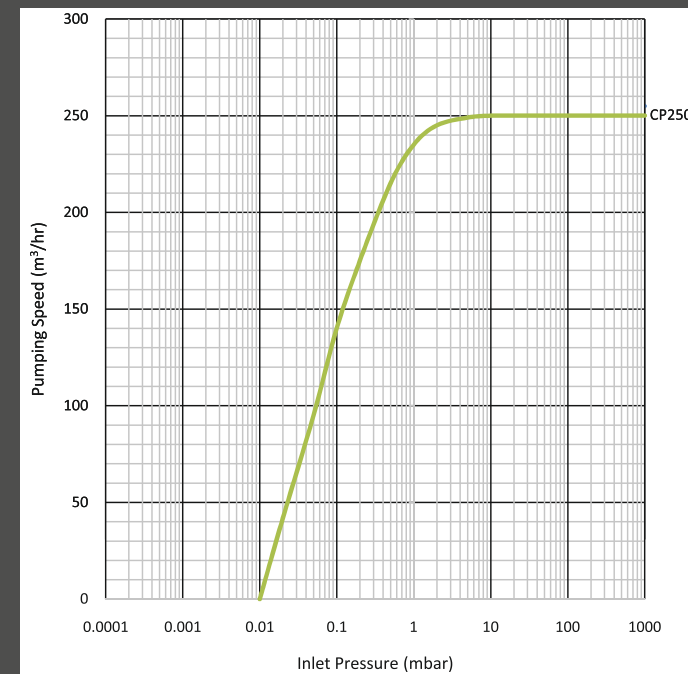

DIMENSIONAL DATA

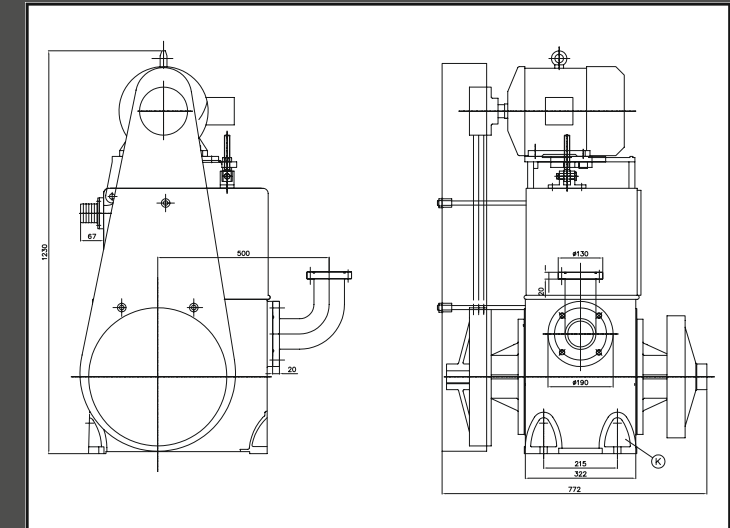

Rugged Belt-Driven Single stage Oil Sealed, Rotary Piston Vacuum Pumps

HHV Pumps CP Series pumps are built to work under strenuous working condition with consistent vacuum performance. CP Series pumps are long lasting in the field which makes them a work horse. These pumps are designed for rough and medium vacuum applications. CP Series pumps are maintenance free and reliable in operation ensuring Lowest Cost of Ownership

FD SERIES
ENGINEERED FOR PERFORMANCE



FEATURES

- » Robust and compact
- » Improved vapor handling performance
- » Forced oil lubrication system with built-in oil vane pump enabling high performance down to 10-3 mbar
- » Quiet operation
- » Minimal vibration
- » Improved inlet port to give maximum flow
- » Lower oil consumption
- » Performance testing in accordance with Pneurop 6602

TYPICAL APPLICATIONS

- » A.C and Refrigeration
- » Research and Development
- » Pharma and Laboratories
- » Lamps, CFL and Tubes
- » Electrical and Power
- » Backing pump for Roots, Turbo, Diffusion and Cryogenic Pumps
- » Leak Detection
- » Coating and Deposition
- » LCMS and GCMS
- » Freeze Drying

DECODING LOGIC

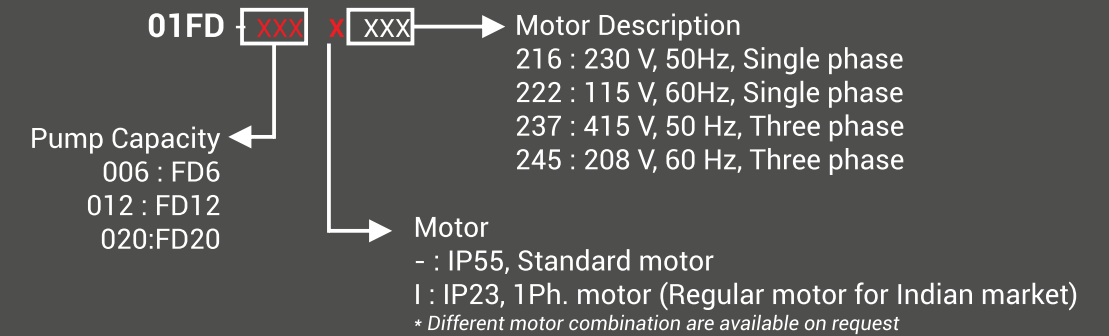

PERFORMANCE CURVES

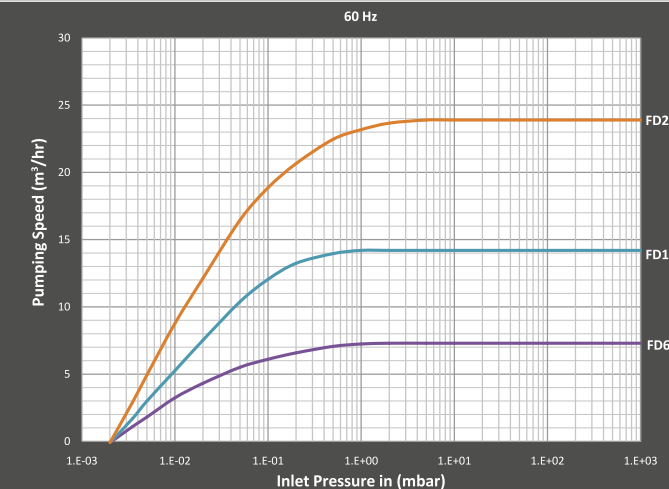
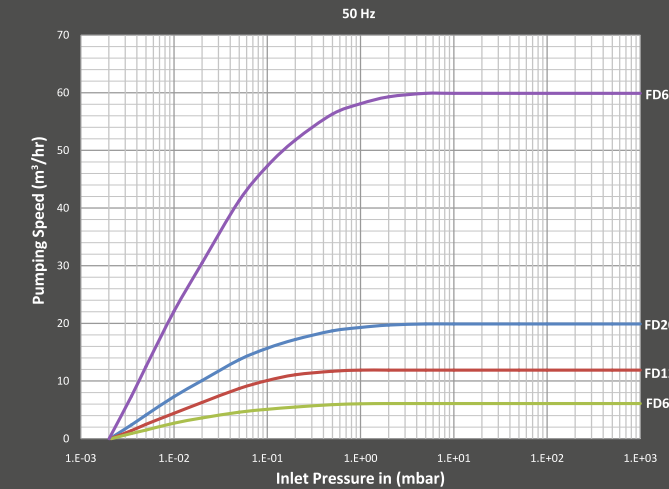

We have developed a new range of double stage vacuum pumps with improved design and smoother operational capability. These pumps are designed for handling high vacuum & medium vacuum applications. FD series pumps are maintenance free and quiet in operation ensuring lowest cost of ownership built to suit global standards.

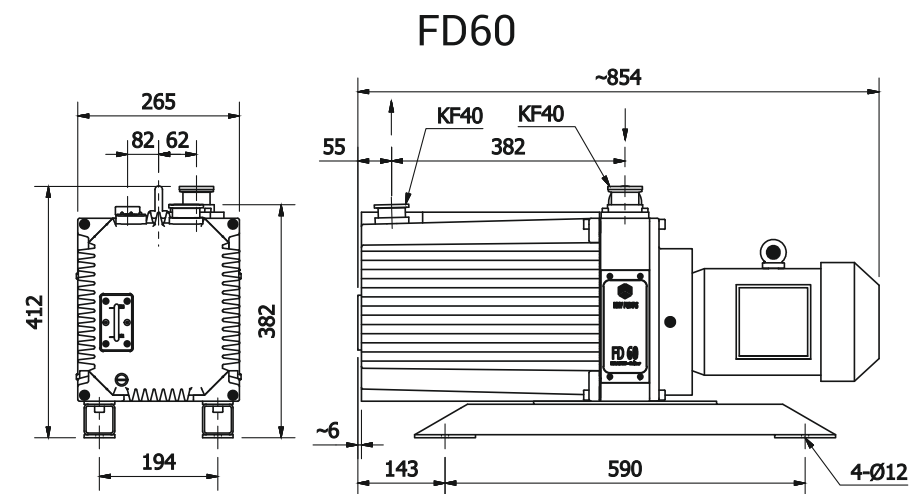

DIMENSIONAL DETAILS FD6,FD12 & FD20

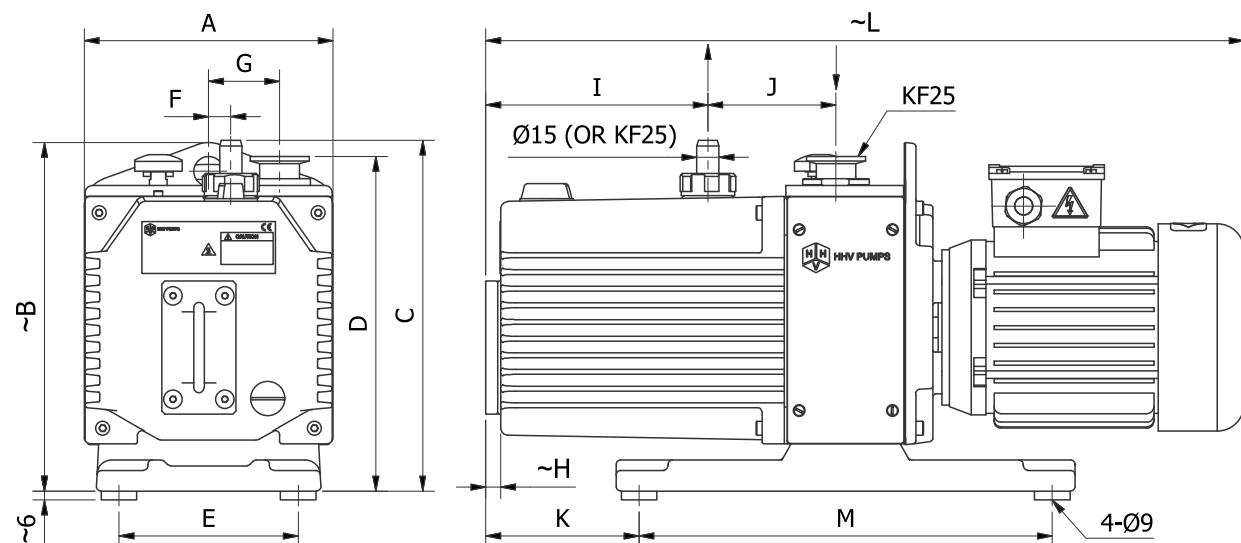

Model	A	B	C	D	E	F	G	H	I	J	K	M
Fd6	168	235	237	226	121	15	48	10	118	86.5	104	279
Fd12	168	235	237	226	121	15	48	10	150	86.5	104	279
Fd20	176	258	251.5	244	139	27.5	51	7	37.5	258.5	151	305

Model	01FD-006-216	01FD-006-222	01FD-006-237	01FD-006-245	01FD-006I245
Overall length 'L'	461	461	480	498	492
Model	01FD-012-216	01FD-012-222	01FD-012-237	01FD-012-245	01FD-012I245
Overall length 'L'	493	533	512	564	524
Model	01FD-020-216	01FD-020-222	01FD-020-237	01FD-020-245	01FD-020I245
Overall length 'L'	593	593	603	618	613

TECHNICAL SPECIFICATIONS

PUMP MODEL		FD6	FD12	FD20	FD60
Nominal Pumping Speed @ 50 Hz	m ³ /hr	6.2	12	20	60
	cfm	3.6	7.1	11.7	35
	L/min	103	200	333	1000
Nominal Pumping Speed @ 60 Hz	m ³ /hr	7.4	14.3	24	NA
	cfm	4.4	8.4	14.1	NA
	L/min	123	238	400	NA
Ultimate pressure	Gas Ballast Closed - mbar (Torr)	2X10 ⁻³ (1.5X10 ⁻³)			
	Gas Ballast Open - mbar (Torr)	5X10 ⁻² (3.75X10 ⁻²)			
Pump Rotational Speed at No-Load @ 50 Hz	rpm	1440			
Pump Rotational Speed at No-Load @ 60 Hz	rpm	1720			NA
Max. Nominal Power Rating @ 50 Hz	kw (HP)	0.37(0.5)	0.37(0.5)	0.55(0.75)	2.2 (3)
	phase	0.37(0.5)	0.37(0.5)	0.55(0.75)	3
Max. Nominal Power Rating @ 60 Hz	kw (HP)	0.37(0.5)	0.37(0.5)	0.55(0.75)	NA
	phase	0.37(0.5)	0.37(0.5)	0.55(0.75)	NA
Power Supply	230V + 10%: 50 Hz + 5% Single phase 415V + 10%: 50 Hz + 5% Three phase 115V + 6%: 60Hz + 3% Single phase 208V + 6%: 60Hz + 3% Three phase				
Weight*	kg (lb)	25.5(56.2)	27.5 (60.6)	35.5 (78.12)	115 (253.5)
Oil Connection	Litres	0.7	0.9	1.2	6
Inlet Connection	KF	Kf25			Kf40
outlet Connection	KF/Nozzle	Kf25 or 1/2" Nozzle			Kf40
Recommended Oil	HHVP Molecular Distilled Oil Grade MD-504				

RD SERIES
ENGINEERED FOR VERSATILITY

RD150
RD300
RD800
RD1700

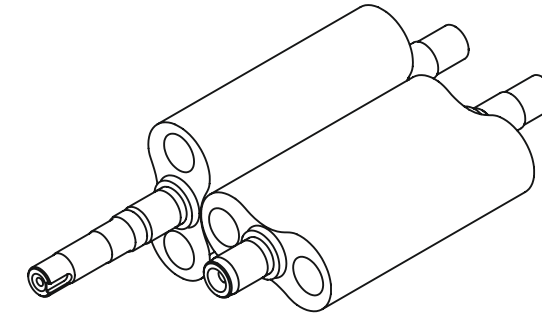

The RD pumps are positive displacement roots vacuum pumps. The pump bearings, gears and seals are lubricated by oil fed from oil reservoirs at either ends of the roots pump. Roots pumps help in shifting the operating pressure to a high vacuum range due to rotation of gear timed rotors in opposite directions. Roots vacuum pumps are capable of improving the attainable ultimate pressure of a pump system by a factor of 10.

Features

- Robust
- Suitable for continuous operation
- Built-in mechanical by pass valve for atmospheric start
- Enhanced performance for longer life
- Pumps are available with flame proof motors
- Customisation of inlet and outlet flanges to suit the requirement
- Improves vacuum
- Self evacuation feature for gear box and motor support area
- All Viton O-rings

Industry/markets

- Pharmaceuticals
- Chemical and Process Industries
- Oil and Gas
- Electrical and Power
- Medical
- Coating
- Heat treatment furnace

Typical Applications

- Vacuum distillation
- Vacuum drying
- Essential oil extraction
- Aromatic extraction
- Oil recycling
- Transformer drying (on-site)
- Transformer oil filtration (on-site)
- Steam/Ethylene Oxide sterilization

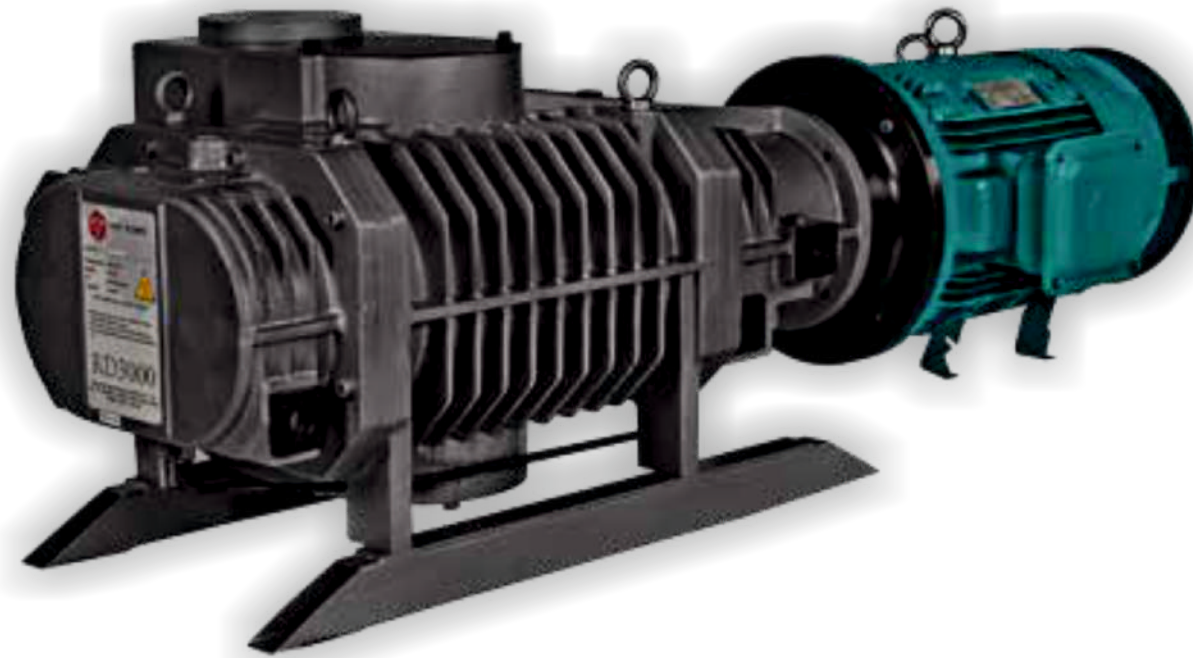

Roots boosters with enhanced performance and longevity

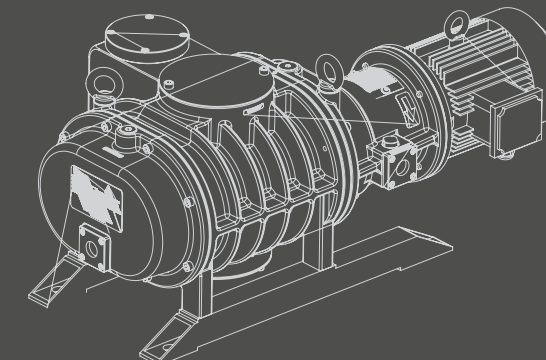

PERFORMANCE CURVES

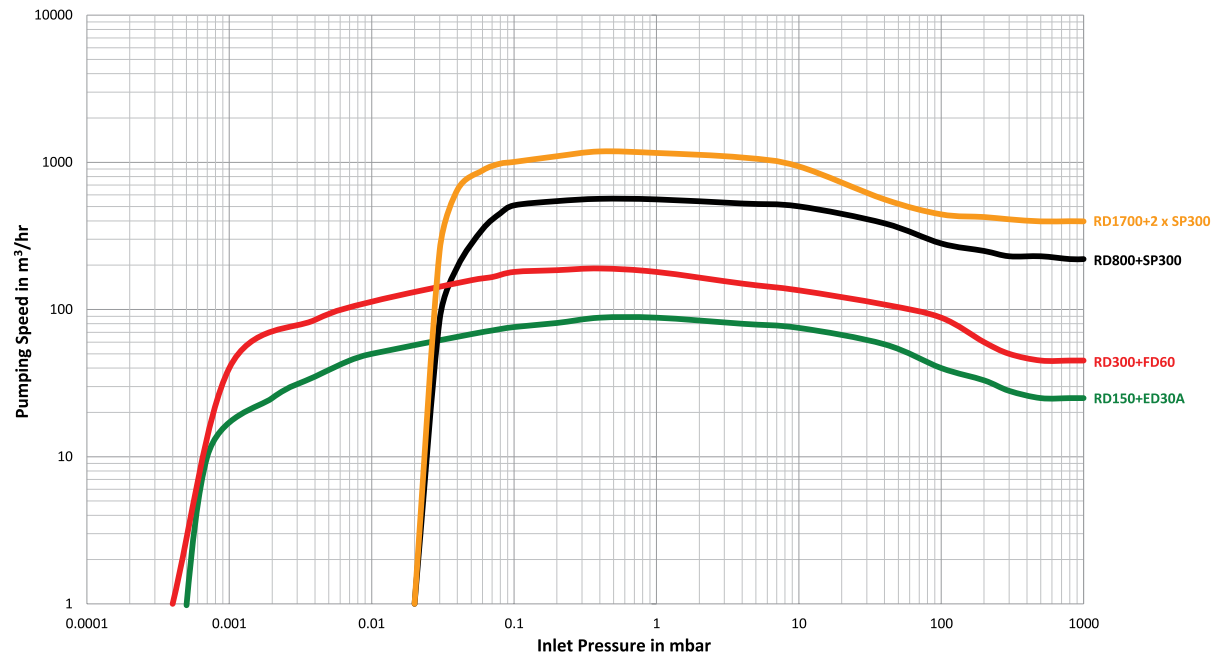

SPECIFICATIONS

Particulars	Unit	RD150	RD300	RD800	RD1700
Nominal pumping speed @ 50Hz	m³/h (L/min)	150 (2501)	300 (5001)	800 (13336)	1700 (28339)
Maximum pumping speed with backing pump	m³/h (L/min)	90 (1500) ED30A	190 (3167) FD60	565 (9419) SP300	1200 (20004) 2 x SP300
Ultimate total pressure	mbar (Torr)	5×10^{-4} (3.75 x 10 ⁴)	5×10^{-4} (3.75 x 10 ⁴)	2×10^{-2} (1.5 x 10 ²)	2×10^{-2} (1.5 x 10 ²)
Recommended backing pumps		ED30A	FD60 SP100*	SP300*	2 x SP300*
Maximum allowable pressure difference	mbar (Torr)	80 (60)	80 (60)	65 (49)	30 (23)
Permissible cut-in pressure	mbar (Torr)	100 (75)	100 (75)	100 (75)	100 (75)
Nominal power rating at 50Hz	kW (HP)	1.1 (1.5)	1.5 (2)	3.7 (5)	7.5 (10)
Motor rotational speed at 50Hz	rpm	1500	1500	1500	1500
Weight	kg (lb)	100 (220)	129 (284)	282 (622)	422 (930)
Inlet connection	ISO	ISO 63	ISO 100	ISO 160	ISO 160
Outlet connection	ISO	ISO 63	ISO 100	ISO 100	ISO 160
Cooling medium		Air	Air	Air	Water
Oil capacity	Lts	0.9	0.9	2	2
Recommended oil		MD504			
Power supply		Three Phase 415V, 50Hz			

* Ultimate total pressure with the single stage backing pumps will be lower as compared with two stage backing pumps

Dimensions

RD150

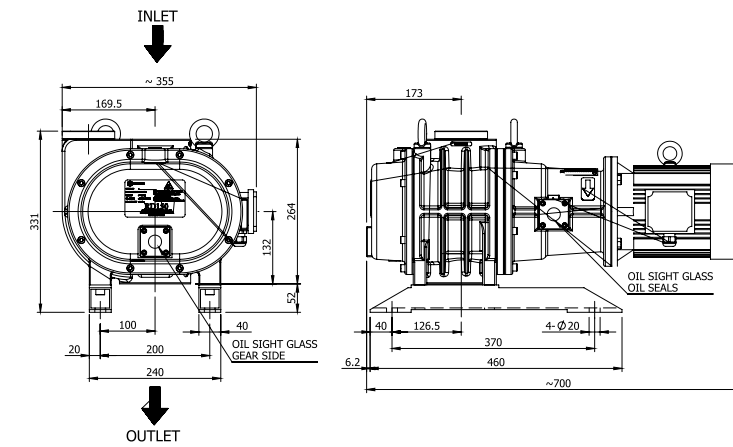

RD300

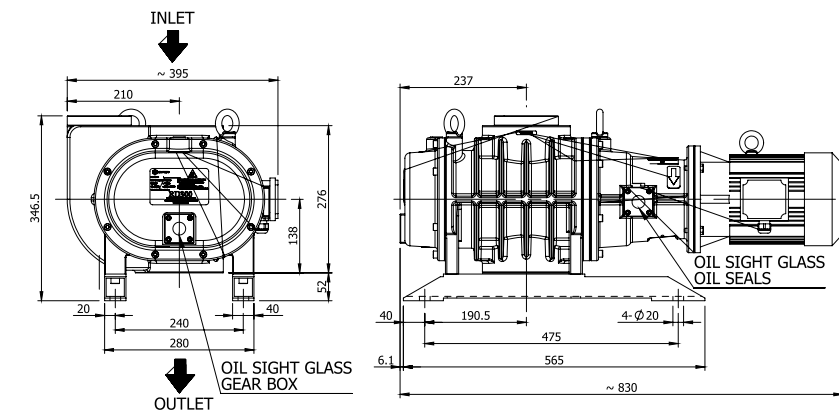

RD800

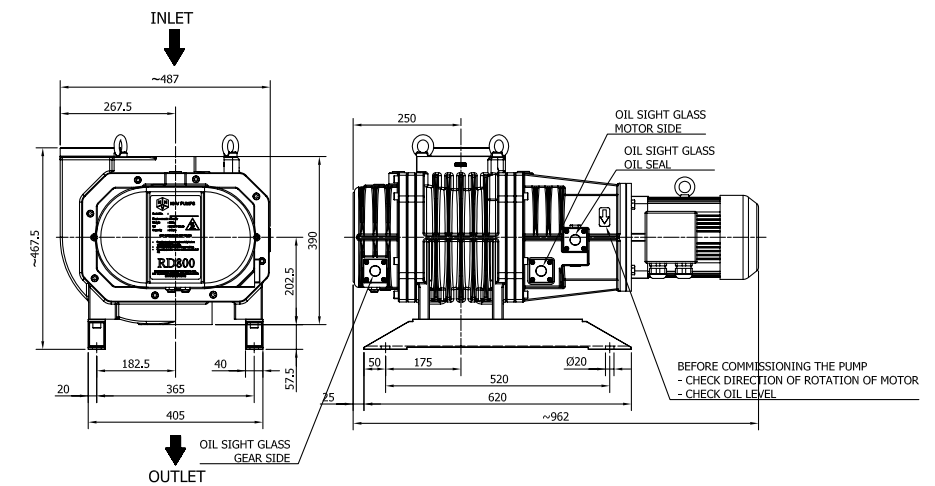

Rd1700

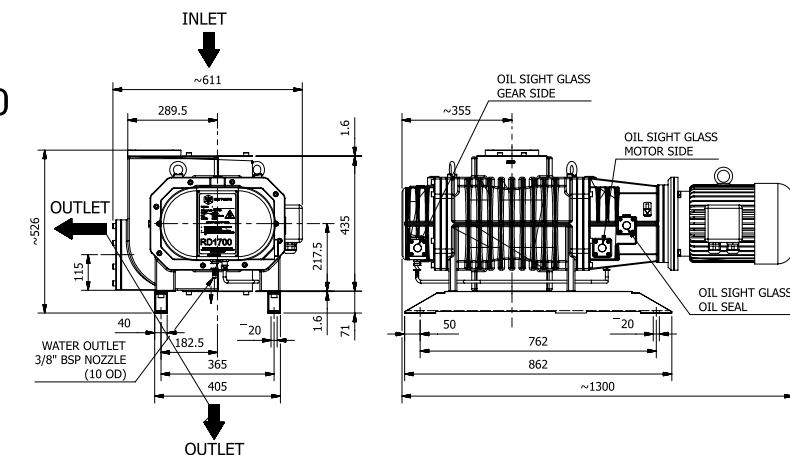

DESIGN/STANDARDIZATION

- » Superior Back Pull Out Design with Manufactured strictly to ANSI B73.1 Chemical Pumps with high reliability/Rigid Construction

PERFORMANCE

- » Volute & Impeller designed to handle/withstand erosive /corrosive liquors Semi- Open/ Open Impellers designed for lower maintenance

SEALING

- » Mechanical Seal can be fitted for sustained performances along with Standard Stuffing Box And We also offer Double Mechanical Seal, Cartridge Mechanicals Seal With Standard Single Mechanical seal.

GCC
CHEMICAL SERIES PUMPS



SERVICES

CHEMICAL, OIL & GAS. POWER SECTOR

- » Non API 610 Chemical & Process Applications
- » General Refinery Services
- » Chemical & Process Transfer
- » Codensates
- » Erosive / Corrosive Liquors

GENERAL INDUSTRY

- » Evaporators
- » Distillations Plant Liquors
- » Mining, Effluent and General Industrial Applications

SECTIONAL VIEW

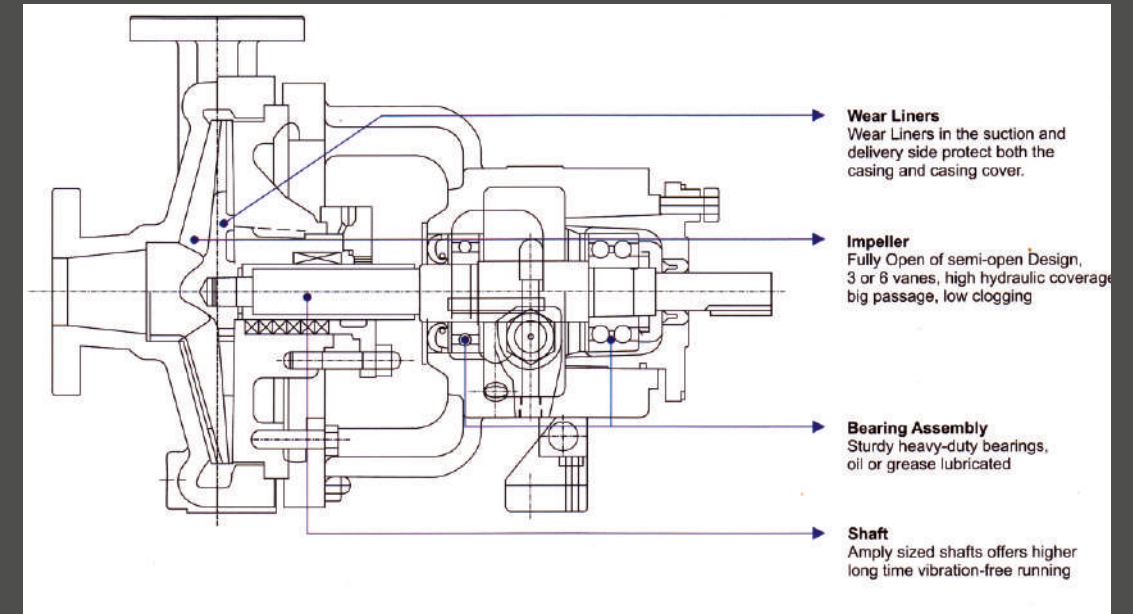

PERFORMANCE CURVES (N=1500 RPM)

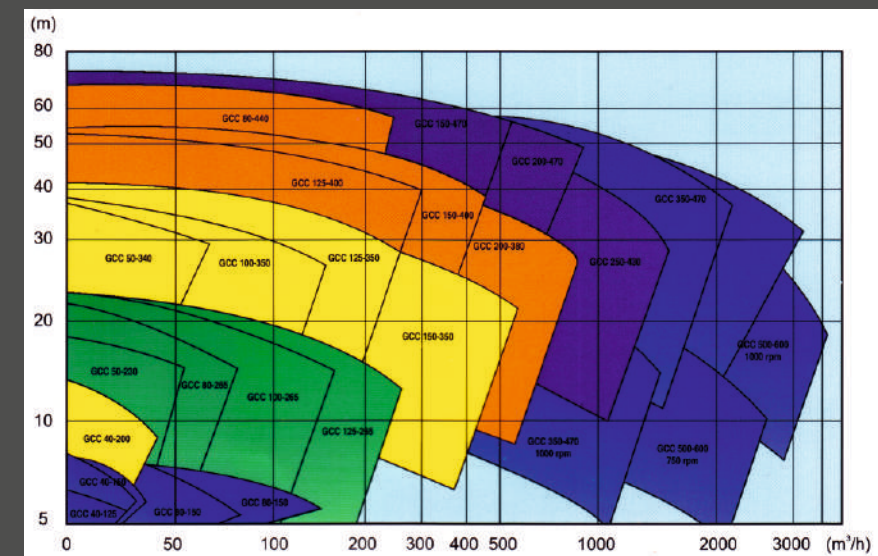

OVERALL RANGE & PERFORMANCE DETAILS

SR. NO.	PUMP MODELS	SUCTION x DELIVERY	FLOW-M3/Hr. (Max)	HEAD-Mtr (Max)
01	GCC-40X125	40X25	28	40
02	GCC-40X150	40X25	32	45
03	GCC-40X200	40X25	45	90
04	GCC-80X150	80X40	55	42
05	GCC-80X150	80X50	90	40
06	GCC-80X265	100X80	80	15
07	GCC-100X265	125X100	130	15
08	GCC-125X265	150X125	200	14
09	GCC-100X350	125X100	130	26
10	GCC-125X350	150X155	220	30
11	GCC-150X330	200X150	400	24
12	GCC-125X400	150X125	225	40
13	GCC-150X400	200X150	380	40
14	GCC-200X380	250X200	650	32
15	GCC-150X470	200X150	550	51
16	GCC-200X470	250X200	700	53
17	GCC-250X430	300X250	1100	41
18	GCC-350X470	350 x 350	1500	45

SR. NO.	ITEM DESCRIPTIONS	SS 304	SS 316	SS 316L	DUPLEX STEEL
1	CASING	SS 304	SS 316	SS 316L	DUPLEX STEEL
2	IMPELLER	SS 304	SS 316	SS 316L	DUPLEX STEEL
3	WEAR PLATE	SS 304	SS 316	SS 316L	DUPLEX STEEL
4	STUFFING BOX	SS 304	SS 316	SS 316L	DUPLEX STEEL
5	SHAFT / SLEEVE	SS 410 / 304 / 316	SS 410 / 304 / 316	SS 410 / 304 / 316	SS 410 / 304 / 316
6	GLAND	SS 304 / 316	SS 304 / 316	SS 304 / 316	DUPLEX STEEL
7	BEARING FRAME ASSEMBLY	CI FG 260	CI FG 260	CI FG 260	CI FG 260
8	PACKING	NON ASBESTOS/PTFE	NON ASBESTOS/PTFE	NON ASBESTOS/PTFE	NON ASBESTOS/PTFE
9	FASTNERS	SS 304	SS 316	SS 316	SS 316

GCP CHEMICAL SERIES PUMPS



TYPICAL APPLICATIONS

- » Paper Stock & Fibrous Pulp
- » White & Black Liquor
- » Food Industry
- » Beverage Industry
- » Chemical Process & Effluents
- » Dewatering & De-inking
- » Transfer & Liquid Distilling
- » Non Edible Food Processing
- » Non Corrosive Effluents & Liquors
- » Liquor Distillation & Transfer
- » Waste Water Treatment
- » Coal

SUPERIOR DESIGN FEATURES

Superior Back Pull Out Design in accordance with internationally Acclaimed Designs - Horizontal Single Stage Type with Superior Efficiency & Low Clogging due to very Robust Designs. Open Impellers are Designed to Specifically handle stocks up to 8% Consistency

CASING

Unique Designs with Top Centerline Discharge & Rigid Constructions with Various Metallurgy to handle Highly Corrosive & Errosive Liquids. Suction & Delivery Flanges are as per DIN & ANSI Standards.

SEALING

Mechanical seal can be fitted for Sustained Performances along with Standard stuffing Box with Value Added Teflon Gland Packings. We also offer Double Mechanical Seal, Catridge Mechanical Seal along with Standard Single Mechanical Seal.

SHAFT

Shaft Design is Very Rigid which can withstand High Radial and Loads for Continuous Operations under Most Severe Conditions. Shaft are Machined on In- House CNC Machines which Guarantees High Accuracy resulting Sustained Performances of Impeler Shaft Assembly over years of operations. Impeller Shaft Assembly is Dynamically Balanced Inhouse at our State of Art Manufacturing Plants on Abro American Fully Computerized Dynamic Balancing machine

QUALITY GUARANTEED

We are Proud to Inform that state or the art manufacturing plant are CE-Certified by UK based SAFATECH & ISO 9001:2008 Certified by German TUV Nord which Assures Each and Every Pump is of highest Quality & Assured Performances.

PERFORMANCE TESTING

Each Pump is Subject to Rigid Testing for its Desired Capacity. head and power consumptions. we have State of the art 100% Computer Controlled PLC based Test Arrangement. Clients are welcome for Testing their Ordered Pumps which are " TOTALLY FREE OF COST "

OVERALL RANGE & OPERATING CONDITION

SR. NO.	MODEL NO.	SUCTION x DELIVERY	FLOW- M3/HR (Max)	HEAD-Mtr (Max)
01	GCP - 80 / 265	100 x 80	85	15
02	GCP - 100 / 265	125 x 100	130	15
03	GCP - 125 / 265	150 x 125	200	15
04	GCP - 100 / 350	125 x 100	105	30
05	GCP - 125 / 350	150 x 125	220	30
06	GCP - 150 / 330	200 x 150	400	24
07	GCP - 125 / 400	150 x 125	240	40
08	GCP - 150 / 400	200 x 150	400	40
09	GCP - 200 / 380	250 x 200	650	32
10	GCP - 150 / 470	200 x 150	550	53
11	GCP - 200 / 470	250 x 200	750	58
12	GCP - 250 / 430	300 x 250	1250	41
13	GCP - 350 / 470	350 x 350	2500	35

SR. NO.	ITEM DESCRIPTIONS	SS 304	SS 316	SS 316L	DUPLEX STEEL
1	CASING	SS 304	SS 316	SS 316L	DUPLEX STEEL
2	IMPELLER	SS 304	SS 316	SS 316L	DUPLEX STEEL
3	WEAR PLATE	SS 304	SS 316	SS 316L	DUPLEX STEEL
4	STUFFING BOX	SS 304	SS 316	SS 316L	DUPLEX STEEL
5	SHAFT / SLEEVE	SS 410 / 304 / 316	SS 410 / 304/ 316	SS 410 / 304/ 316	SS 410 / 304/ 316
6	GLAND	SS 304 / 316	SS 304 / 316	SS 304 / 316	DUPLEX STEEL
7	BEARING FRAME ASSEMBLY	CI FG 260	CI FG 260	CI FG 260	CI FG 260
8	PACKING	NON ASBESTOS/PTFE	NON ASBESTOS/PTFE	NON ASBESTOS/PTFE	NON ASBESTOS/PTFE
9	FASTNERS	SS 304	SS 316	SS 316	SS 316

GHV

OIL SEALED ROTARY HIGH VACUUM PUMPS



PRINCIPAL OF OPERATION

These are oil-immersed rotary vane type pumps. The rotor, with two spring loaded vanes, is mounted eccentric in the stator body, As the rotor, rotates the vanes sweep the crescent shape, air twice in each revolution. There is in-built non-return valve which prevents back flow of air, Manufactured from graded material, all moving parts are precisely machined, ground and assembled with close tolerances. This results in increased efficiency and long trouble free operating life.

APPLICATION

- » Distillation *Dehydration and Filtration processes.
- » GLS Lamps *Mercury Vapour Lamps & Tubes.
- » Exhausting Electronic Tube
- » Refrigerator and Air-conditioner Servicing
- » Freeze Drying of Foods. *Vacuum Metallurgy
- » Vacuum Sublimation *Vacuum Impregnation *Thin film Coating.

ACCESSORIES

- » AIR-BALLAST:OPTIONAL:
This is a vent introducing air before actual compression which eliminates condensation of the sucked vapour, Their by avoiding contamination of oil.
- » AIR ADMITTANCE VALVE : OPTIONAL:
It is electromagnetic solenoid type which admits air into the system as soon as the power supply fails. This prevents back-flow of oil to the system.
- » NON-RETURN VALVE : OPTIONAL:
It is rubber diaphragm type, spring loaded valve, which prevents back-flow of oil to the system as soon as pump stops. There can not be used to hold the vacuum in the system for longer period.
- » Moisture trap *inlet Dust *Vacuum Gauge with Regulator * Trolley For small Pumps-Optional
- » USE OIL : ENCLO-46(H.P) /SAF-30 or Equivalent,
- » Model GHV-300-II and above are provided with water cooling jacket.
- » Vacuum measured Mcleod gauge at suction port of the Pump

Model No.	No.Of Stages	Free Air Displacement		Ultimate Vacuum mm of Rg.	Drive Motor Raqd. H.P	Approx Oil Filtering Ltrs
		Lt./Min.	C.F.M.			
GHV-50	1	50	1.8	0.05	0.25	2
	2	50	1.8	0.005	0.25	2
GHV-100	1	100	3.5	0.05	0.25	2
	2	100	3.5	0.005	0.5	3
GHV--150	1	150	5.3	0.05	0.5	4
	2	150	5.3	0.005	1.0	4.5
GHV-300	1	300	10.6	0.05	1.0	6
	2	300	10.6	0.005	1.5	8
GHV-500	1	500	17.6	0.05	1.5	8
	2	500	17.6	0.005	1.5	8
GHV-750	1	750	26.5	0.05	2.0	10
	2	750	26.5	0.005	3.0	10
GHV-1000	1	1000	35.3	0.05	3.0	18
	2	1000	35.3	0.005	3.0	18
GHV-1500	1	1500	53.0	0.05	3.0	20
	2	1500	53.0	0.005	3.0	25
GHV-2000	1	2000	75.5	0.05	5.0	25
	2	2000	75.5	0.005	5.0	30
GHV-3000	1	3000	106.0	0.05	5.0	33
	2	3000	106.0	0.005	7.5	40
GHV-5000	1	5000	177.0	0.05	7.5	40
	2	5000	177.0	0.005	10.0	45
GHV-7500	1	7500	265.0	0.05	10.0	50
	2	7500	265.0	0.005	15.0	55
GHV-10000	1	10000	353.0	0.05	15.0	50
	2	10000	353.0	0.005	20.0	60
GHV-15000	1	15000	530.0	0.05	25.0	85
	2	15000	530.0	0.005	25.0	95
GHV-20000	1	20000	706.0	0.05	25.0	100
	2	20000	706.0	0.005	30.0	110

GDS

TWO STAGE WATER-RING VACUUM PUMPS

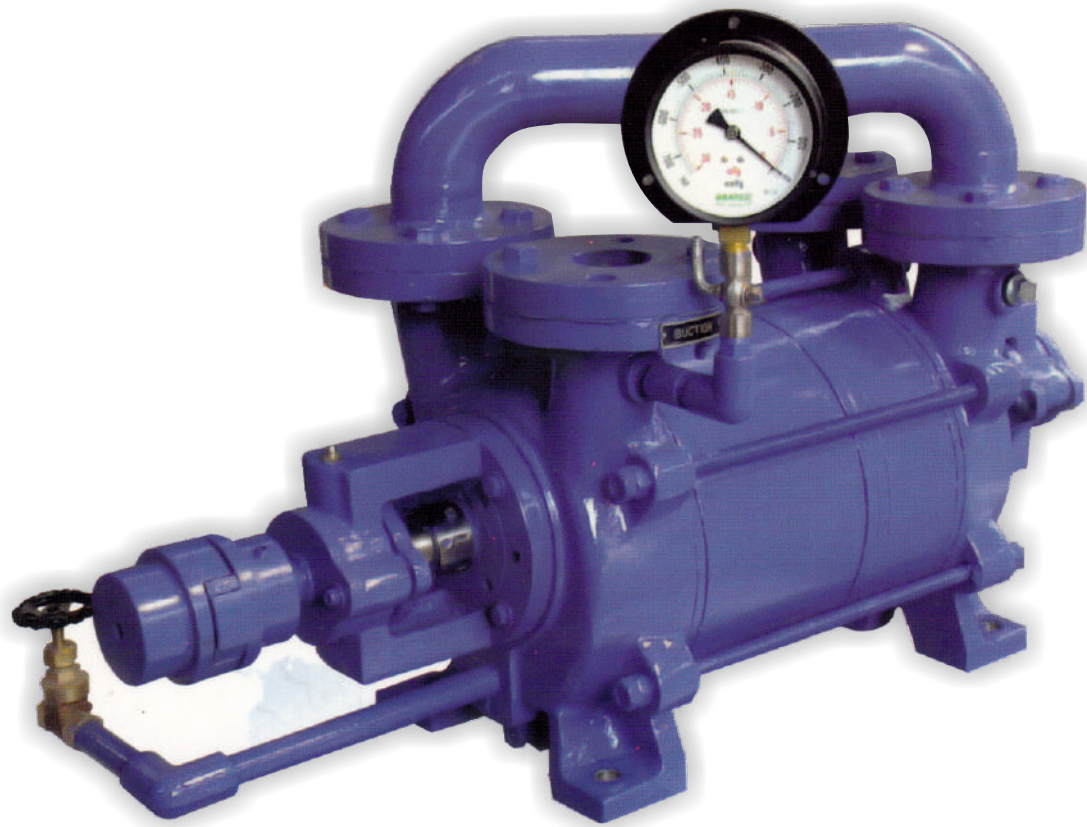

SUCTION CAPACITY / AIR DISPLACEMENTS:

- » 40 CFM - 750 CFM Guaranteed Capacity
- » 720 mm of Hg Vacuum Guaranteed
- » 3 Kw to Motor Ratings

MATERIAL OF CONSTRUCTION

- » Capacity Standard Cast Iron FG-260 to IS 210 SG Iron
- » Stainless Steel 304 / 316 / 304 L / 316 L / 410 / 420
- » Phosphorous Bronze 90/10, Gun Metal
- » Aluminium Bronze / Alloy 20/ Available in Partial / Lined or complete Construction

TESTING STANDARDS

- » Pneurope Ltd
- » BS 1571 Pt-2
- » Orifice Method to HES Standards

OVERALL RANGE & OPERATING CONDITION

Pump Model	Max. Cap. (M ³ /hr)	Water Req. (LPM)	Rec. Motor HP / Speed
GDS-5	81	7	5/2800
GDS-75	160	9	7.5/1500
GDS-100	220	14	10/1500
GDS-115	330	20	15/1500
GDS-120	440	24	20/1500
GDS-125	625	30	25/1500
GDS-130	750	40	30/1500
GDS-140	1200	50	40/1500
GDS-150	1500	60	50/1500

Garuda Two stage Liquid ring Vacuum Pumps are manufactured at the state-of-the-art manufacturing plants with superior 100% in-house facilities in adherence with iso 9001:2008 certification by TuV Nord of Germany.

These Pumps are guaranteed for Vacuum up to 720 mm Hg with seal water 30°C temperature at Barometric Pressure of 755 mm of Hg suction inlet temperature of 30°C. Higher vacuum of 735 mm Hg can be achieved with seal water 15°C to 18°C. This is we call "**HIGHER CAPACITY @ HIGH VACUUM**" with reduced quantity of seal water is achieved by using superior "**INVESTMENT CASTINGS**"

GWV
LIQUID RING VACUUM PUMPS



MATERIAL OF CONSTRUCTION

Cast Iron FG-260 S.G Iron / Phosphorous Bronze / SS-316 / SS- 304 SS-316L Lined / Cast Steel Alloy 20 in Complete as well as Partial Vacuum Pumps

TESTING STANDARDS

Each pump is subject to rigorous test runs at our Solid Concrete Test Bed facilities in accordance with HEI Standards for LRVP's (NASH ORIFICE METHOD) / BS 1571 PT - 2 PNEUROPE LTD. Authenticating the Power, Vacuum and Air Displacement Parameters, each pump is certified for its performance.

LAYOUT DIAGRAM

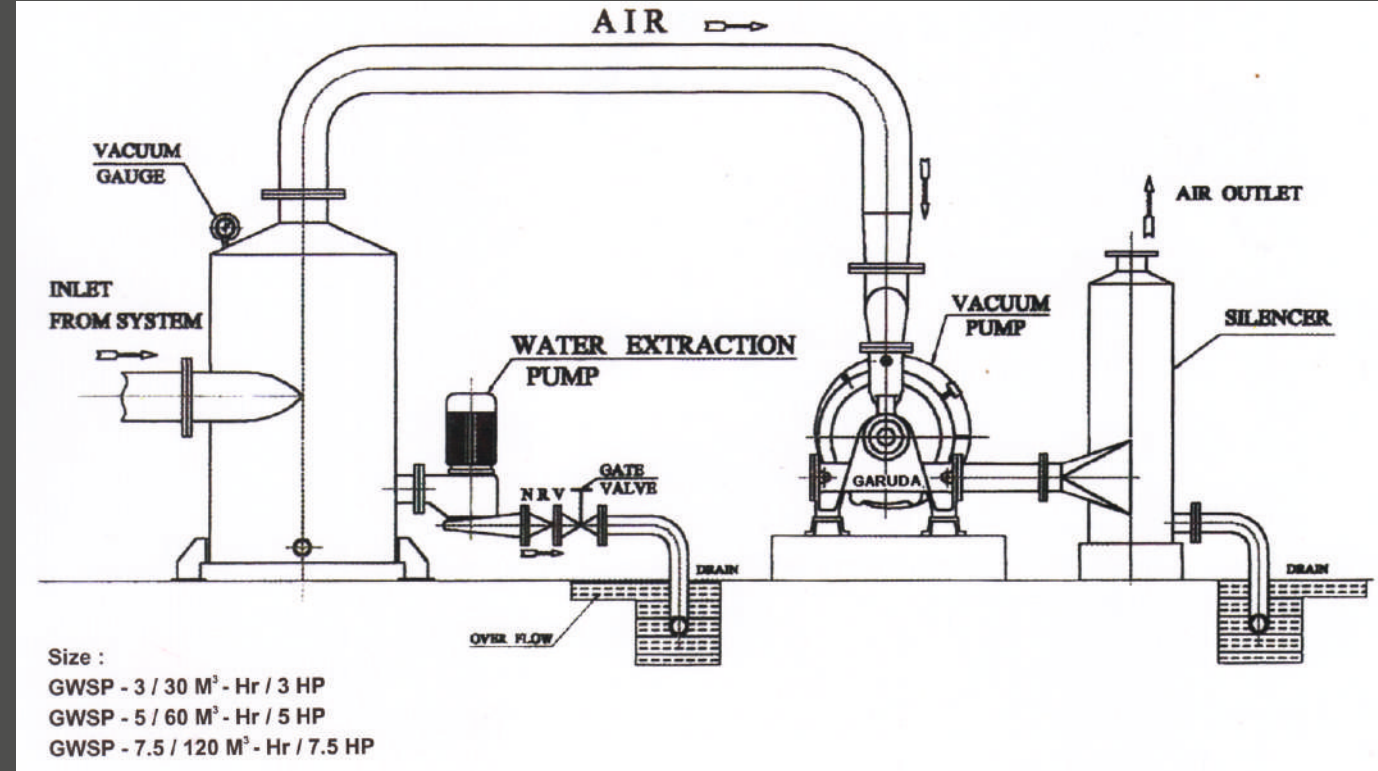

PERFORMANCE TABLE OF "GARUDA" GWV SERIES

MODEL	MOTOR HP	SPEED (RPM)	SUCTION CAPACITY m3 / hr	WATER LPM
GWV 10	1	2880	10	1.2
GWV 20	2	2880	20	2.0
GWV 40	3	2880	53	4.0
GWV 70	5	2880	85	9.0
GWV 120	7.5	2880	125	13.0
GWV 150	7.5	1440	175	16.0
GWV 200	10	1440	225	20.0
GWV 300	15	1440	340	28.0
GWV 400	20	1440	450	35.0
GWV 500	25	980	525	45.0
GWV 600	30	980	730	55.0
GWV 1000	40	980	1100	85.0
GWV 1500	75	725	1725	120
GWV 2000	100	725	2200	150